

Draft

Digital Printing Working Group Integrated Digital Printing ICS **Application Note**

Date: 12 March 2004

Version **V0.26**

File: **DP-ICS-and-AppNote-v26-09-Mar-2004.doc, .pdf**

ICSVersion: **DP_L1-1.0**

Revisions are in **red** with change bars in the right margin.
The open ISSUES are **highlighted in green**.

Abstract

This CIP4 JDF Interoperability Conformance Specification (ICS) defines the interoperability requirements for a subset of JDF defined as Level 1 Integrated Digital Printing. Level 1 is useful for color and black and white integrated digital printing systems with in-line finishing capabilities. It encompasses production printing IPP semantics.



Copyright Notice

Copyright © 2000-2004, International Cooperation for Integration of Processes in Prepress, Press and Postpress, hereinafter referred to as CIP4. All Rights Reserved

Permission is hereby granted, free of charge, to any person obtaining a copy of the Specification and associated documentation files (the “Specification”) to deal in the Specification, including without limitation the rights to use, copy, publish, distribute, and/or sublicense copies of the Specification, and to permit persons to whom the Specification is furnished to do so, subject to the following conditions. The above copyright notice and this permission notice must be included in all copies or substantial portions of the Specification.

THE SPECIFICATION IS PROVIDED “AS IS”, WITHOUT WARRANTY OF ANY KIND, EXPRESS, IMPLIED, OR OTHERWISE, INCLUDING BUT NOT LIMITED TO THE WARRANTIES OF MERCHANTABILITY, FITNESS FOR A PARTICULAR PURPOSE AND NONINFRINGEMENT. IN NO EVENT WILL CIP4 BE LIABLE FOR ANY CLAIM, DAMAGES OR OTHER LIABILITY, WHETHER IN AN ACTION OF CONTRACT, TORT OR OTHERWISE, ARISING FROM, OUT OF, OR IN CONNECTION WITH THE SPECIFICATION OR THE USE OR OTHER DEALINGS IN THE SPECIFICATION.

Except as contained in this notice or as allowed by membership in CIP4, the name of CIP4 must not be used in advertising or otherwise to promote the use or other dealings in this Specification without prior written authorization from CIP4.

Licenses and Trademarks

International Cooperation for Integration of Processes in Prepress, Press and Postpress, CIP4, Job Description Format, JDF and the CIP4 logo are trademarks of CIP4.

Rather than put a trademark symbol in every occurrence of other trademarked names, we state that we are using the names only in an editorial fashion, and to the benefit of the trademark owner, with no intention of infringement of the trademark.

Table of Contents

Copyright Notice.....	2
Licenses and Trademarks	2
1 Introduction.....	7
1.1 Reference Model and Digital Printing	7
1.2 Overview of JDF.....	9
1.2.1 What is JDF?.....	9
1.2.2 Elements in a JDF Job Ticket.....	9
1.2.3 Structure and Content of a JDF Job Ticket	11
1.3 Digital Printing Job Ticket.....	12
1.4 Conformance Interface, Producer, and Consumer	13
1.5 Scope.....	13
2 Terminology	14
2.1 Conformance Terminology.....	15
2.2 Other Terminology	15
3 JDF Supported by Integrated Digital Printing ICS.....	16
3.1 Combined Digital Printing Node	16
3.1.1 Settings Policy.....	16
3.1.2 Conformance Levels.....	16
3.1.3 Processes	16
3.1.4 Combined Digital Printing Node Attributes.....	20
3.1.5 Elements Included in a Combined Digital Printing Node.....	20
3.1.6 Resources.....	21
3.1.7 Structure and Content of a Digital Printing JDF Job Ticket.....	24
3.1.8 JDF Conformance Tables for Integrated Digital Printing ICS.....	27
3.2 Features Supported	70
3.2.1 Approval.....	72
3.2.2 Billing Code.....	74
3.2.3 Binding.....	74
3.2.4 Black Overprint.....	76
3.2.5 Collate.....	77
3.2.6 Comment/Description of Job	77
3.2.7 Contact Information.....	78
3.2.8 Covers	80
3.2.9 Destination or Physical Printer Requested.....	83
3.2.10 Destination or Physical Printer Resolution	83
3.2.11 Document Compression.....	84
3.2.12 Document File Format.....	85
3.2.13 Document File Name	87
3.2.14 Document Natural Language.....	88
3.2.15 Feed Orientation.....	89
3.2.16 Fit Policy.....	90
3.2.17 Folding.....	91
3.2.18 Force Page.....	93
3.2.19 Hold Job.....	95
3.2.20 ICS Versions	96
3.2.21 Image Shift Back Side	96
3.2.22 Image Shift Front Side	96
3.2.23 Input Tray Name	97
3.2.24 Insert Sheet	99
3.2.25 Interleave Sheets.....	100

3.2.26	<i>Job Created By</i>	101
3.2.27	<i>Job Identification</i>	102
3.2.28	<i>Job Modified By</i>	102
3.2.29	<i>Job Name</i>	103
3.2.30	<i>Job Priority</i>	103
3.2.31	<i>Job Ticket Created By</i>	104
3.2.32	<i>Job Ticket Template Comment or Description</i>	104
3.2.33	<i>Job Ticket Template ID</i>	105
3.2.34	<i>Job Ticket Template Version</i>	105
3.2.35	<i>Jog Offset</i>	106
3.2.36	<i>Margins</i>	106
3.2.37	<i>Media</i>	107
3.2.38	<i>Message to Operator</i>	112
3.2.39	<i>MIS Support</i>	113
3.2.40	<i>Named Features</i>	113
3.2.41	<i>Notification</i>	114
3.2.42	<i>Number of Copies</i>	115
3.2.43	<i>Number Up</i>	115
3.2.44	<i>Output Bin Name</i>	118
3.2.45	<i>Page Delivery</i>	119
3.2.46	<i>Page Distribution</i>	119
3.2.47	<i>Page Order</i>	120
3.2.48	<i>Presentation Direction</i>	120
3.2.49	<i>Print Quality</i>	121
3.2.50	<i>Process Color Model</i>	121
3.2.51	<i>Proof Print</i>	122
3.2.52	<i>Punching and Hole Making</i>	124
3.2.53	<i>Range of Pages to Include</i>	125
3.2.54	<i>Range of Pages to Output</i>	127
3.2.55	<i>Rotate Sheet Content</i>	129
3.2.56	<i>Screening</i>	129
3.2.57	<i>Settings Policy</i>	130
3.2.58	<i>Sides</i>	131
3.2.59	<i>Spot Color</i>	132
3.2.60	<i>Stapling and Stitching</i>	132
3.2.61	<i>Start, Separator/Slip, End Sheets</i>	134
3.2.62	<i>Trapping</i>	136
3.2.63	<i>Trimming</i>	136
4	Conformance Requirements for <fill in your ICS>	137
4.1	Conformance Requirements for Controller/Agents	137
4.2	Conformance Requirements for Devices	137
5	References	137
5.1	Normative References.....	137
5.2	Informative References.....	138
6	Contributors	138
7	Author's Address	138
Annex A	<Changes to Consider for JDF 1.3> (Informative)	139
Annex B	<Additions to Consider for Next Release of ICS> (Informative)	140
	Change Log (Informative)	141

B.1	Changes to make version 0.01, January 31, 2003	141
B.2	Changes to make version 0.02, March 2, 2003	141
B.3	Changes to make version 0.03, March 17, 2003	142
B.4	Changes to make version 0.04, March 24, 2003	142
B.5	Changes to make version 0.05, April 16, 2003	143
B.6	Changes to make version 0.06, May 23, 2003	144
B.7	Changes to make version 0.07, June 10, 2003	145
B.8	Changes to make version 0.08, August 22, 2003	145
B.9	Changes to make version 0.09, October 7, 2003	146
B.10	Changes to make version 0.09, October 14, 2003	146
B.11	Changes to make version 0.10, October 21, 2003	146
B.12	Changes to make version 0.11, November 14, 2003	146
B.13	Changes to make version 0.12, November 21, 2003	147
B.14	Changes to make version 0.13, December 8, 2003	147
B.15	Changes to make version 0.14, December 15, 2003	147
B.16	Changes to make version 0.15, January 9, 2004	148
B.17	Changes to make version 0.16, January 12, 2004	149
B.18	Changes to make version 0.17, January 15, 2004	149
B.19	Changes to make version 0.18, February 05, 2004	150
B.20	Changes to make version 0.19, February 06, 2004	150
B.21	Changes to make version 0.20, February 13, 2004	151
B.22	Changes to make version 0.21, February 18, 2004	153
B.23	Changes to make version 0.22, February 20, 2004	153
B.24	Changes to make version 0.23, March 02, 2004	154
B.25	Changes to make version 0.24, March 05, 2004	155
B.26	Changes to make version 0.25, March 09, 2004	156
B.27	Changes to make version 0.26, March 12, 2004	156

Table of Figures

Figure 1-1 Reference Model and Digital Printing	8
Figure 1-2 Job Ticket Conceptual View	10
Figure 1-3 Process and Resource Relationship	10
Figure 1-4 Structure of a JDF Job Ticket	11
Figure 1-5 Example of JDF and JMF workflow interactions	13
Figure 3-1 Process and Resource Flow	19
Figure 3-2 Structure of a Digital Printing Job Ticket	24

Table of Tables

Table 1 - Possible successor processes of each predecessor process	17
Table 2 - Combined Digital Printing Node Child Elements and Number of Occurrences	20
Table 3 - Supported Processes and their Resources	21
Table 4 - Number of Occurrences of Supported Resources	22
Table 5 JDF (Combined Digital Printing Node)	27
Table 6 All Elements (except Combined Digital Printing Node)	29
Table 7 All Resources	30
Table 8 All ResourceLink elements	30
Table 9 All ResourceRef elements	30
Table 10 Address	31
Table 11 ApprovalParams	31
Table 12 ApprovalPerson	31
Table 13 ApprovalSuccess	32
Table 14 AuditPool	32

Table 15 AutomatedOverPrintParams	32
Table 16 ColorantControl	33
Table 17 ColorantParams	33
Table 18 ComChannel	33
Table 19 Comment	34
Table 20 Company	35
Table 21 Component	35
Table 22 ComponentLink	36
Table 23 Contact	36
Table 24 CoverApplicationParams	37
Table 25 CustomerInfo	37
Table 26 CustomerMessage	38
Table 27 Device	38
Table 28 DigitalPrintingParams	39
Table 29 Disjointing	40
Table 30 FileSpec	40
Table 31 FitPolicy	42
Table 32 FoldingParams	42
Table 33 HoleMakingParams	43
Table 34 ImageShift	43
Table 35 InsertSheet	44
Table 36 InterpretingParams	45
Table 37 JobField	46
Table 38 LayoutElement	46
Table 39 LayoutPreparationParams	47
Table 40 Location	48
Table 41 MarkObject	48
Table 42 Media	49
Table 43 MediaLink	51
Table 44 MediaRef	51
Table 45 NodeInfo	51
Table 46 ObjectResolution	52
Table 47 Part	52
Table 48 Person	52
Table 49 PageCell	53
Table 50 RenderingParams	53
Table 51 ResourceLinkPool	54
Table 52 ResourcePool	55
Table 53 RunList	56
Table 54 RunListLink	57
Table 55 ScreeningParams	58
Table 56 ScreenSelector	58
Table 57 SeparationSpec	58
Table 58 Sheet	59
Table 59 SpineTapingParams	59
Table 60 StitchingParams	59
Table 61 Surface	60
Table 62 TrappingDetails	60
Table 63 TrimmingParams	61
Table 64 Partitioning RunList	62
Table 65 Partitioning Resources other than RunList	63

1 Introduction

JDF (Job Definition Format) describes a job from conception through delivery. A job ticket can be used to specify the entire workflow or part of the workflow. This Interoperability and Conformance Specification (ICS) for Digital Printing defines subsets of JDF necessary to describe what a JDF producer (JDF Controller/Agent) can direct a JDF consumer (JDF Device) to do, such as printing, hole making, folding, imposition, etc.

The CIP4 JDF Specification [JDF] defines all valid JDF and JDF syntax can be found at www.cip4.org.

JDF is a very comprehensive job ticket format that allows for many different ways to specify a digital print job. To minimize complexity and to better guarantee interoperability between JDF producers and consumers, this ICS identifies a relatively small subset of JDF for Digital Printing.

This ICS defines a subset of JDF referred to as Level 1.. Level 1 is useful for color and black and white integrated digital printing systems with in-line finishing capabilities. It encompasses production printing IPP semantics.

A companion Integrated Digital Printing Application Note [DP-AppNote] explains this ICS in more detail, but does not contain any normative material, i.e., does not contain any material that defines conformance to this ICS.

See Chapter 1 in [JDF] for an introduction to JDF. Recommended reading:

- 1.1 Background in JDF
- 1.4 Glossary of Terminology
- 1.5 Data Structures
- 1.6 Units

1.1 Reference Model and Digital Printing

The function in an Integrated Digital Printer can be modeled as a combination of Prepress, Press, and Postpress. This application note describes the interface for an Integrated Digital Printer which is the dashed line in the following Reference Model diagram.

Figure 1-1 Reference Model and Digital Printing

Symbols and Notation

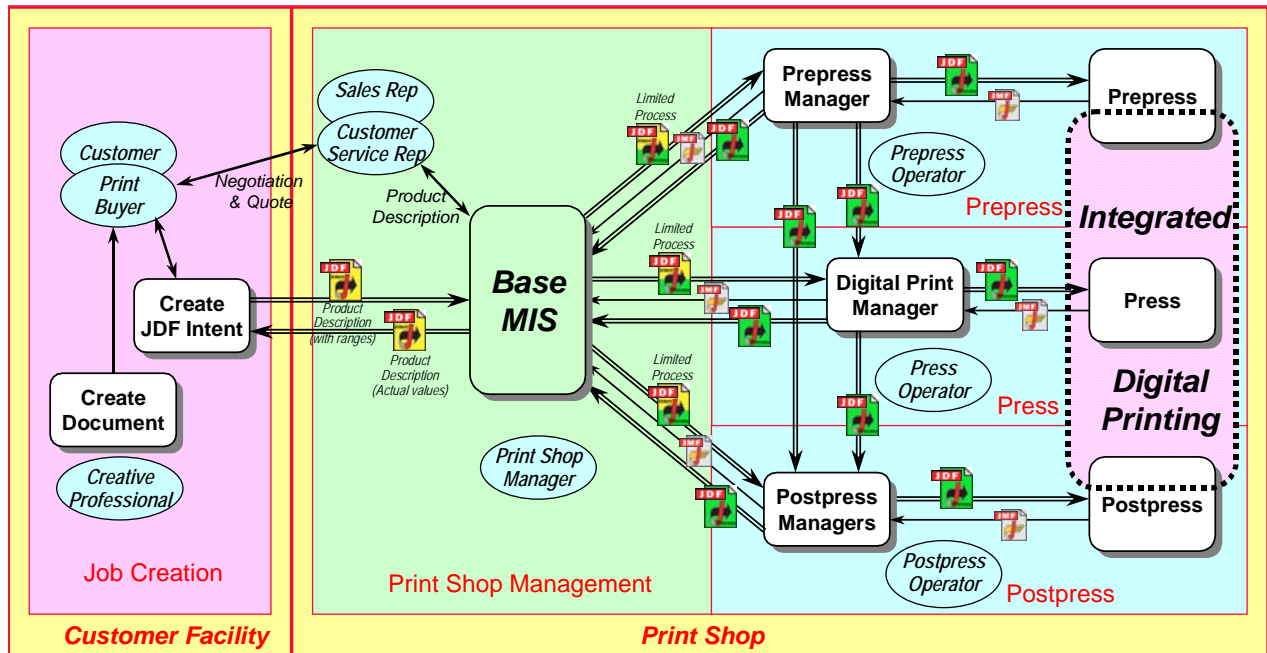
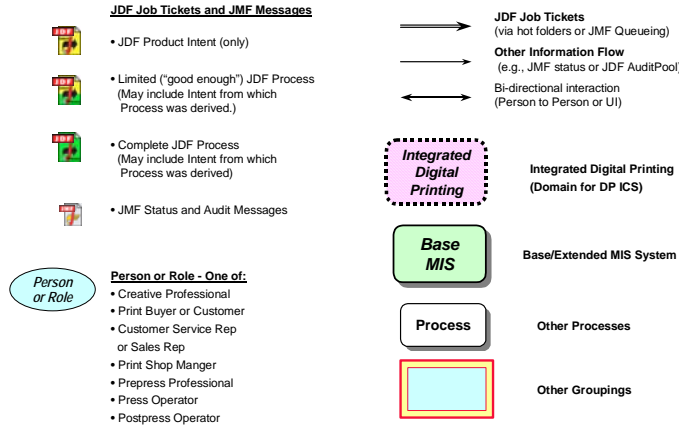

1.2 Overview of JDF

1.2.1 What is JDF?

JDF is an extensible, XML-based job ticket format used by the printing industry. It has the ability to unify the pre-press, press, and post-press aspects of a printing job and provides the means to bridge the communication gap between MIS (Management Information Services) and Production Services. MIS oversees the relationship between all of the units in a workflow and is responsible for planning and controlling the job. Production Services is responsible for the operation of the job. JDF provides a way to describe a job from the time that a customer places the order until the time that the finished product is placed in the customer's hands.

JDF was developed and is maintained by CIP4 (International Cooperation for Integration of Processes in Prepress, Press, and Postpress) which is an international world wide operating standards body whose purpose is to encourage computer based integration of all processes that have to be considered in the graphics arts industry.

JDF is a vendor-independent XML-based data format. JDF is not a product or application, it is a technology that can be incorporated into a product or application. As an extensible format it can easily be tailored to meet vendor-specific product requirements and capabilities. JDF does not dictate that a workflow must be constructed in any pre-specified way; its flexibility allows JDF to be used to model custom solutions. JDF is equally as effective with a simple system such as submitting a job to a printer.

See Chapter 2 in [JDF] for an overview of JDF. Recommended reading:

- o 2.1 System Components
- o 2.2 JDF WorkFlow
- o 2.3 Hierarchical Tree Structure and Networks in JDF

1.2.2 Elements in a JDF Job Ticket

ISSUE: Should most or all of this section be removed and instead refer to the JDF Spec, chapter 2?

There is a conceptual view of a JDF job ticket and an actual view. The conceptual view is the model on which a JDF job ticket is built where a JDF job ticket comprises one JDF node that may contain one or more other JDF nodes. Each of these JDF nodes may comprise one or more processes, and resources that are inputs to and outputs from processes. The actual or physical view of a JDF job ticket is how the document that contains the JDF XML is physically structured and what it contains.

Following is a diagram of the conceptual view of a JDF job ticket:

Figure 1-2 Job Ticket Conceptual View

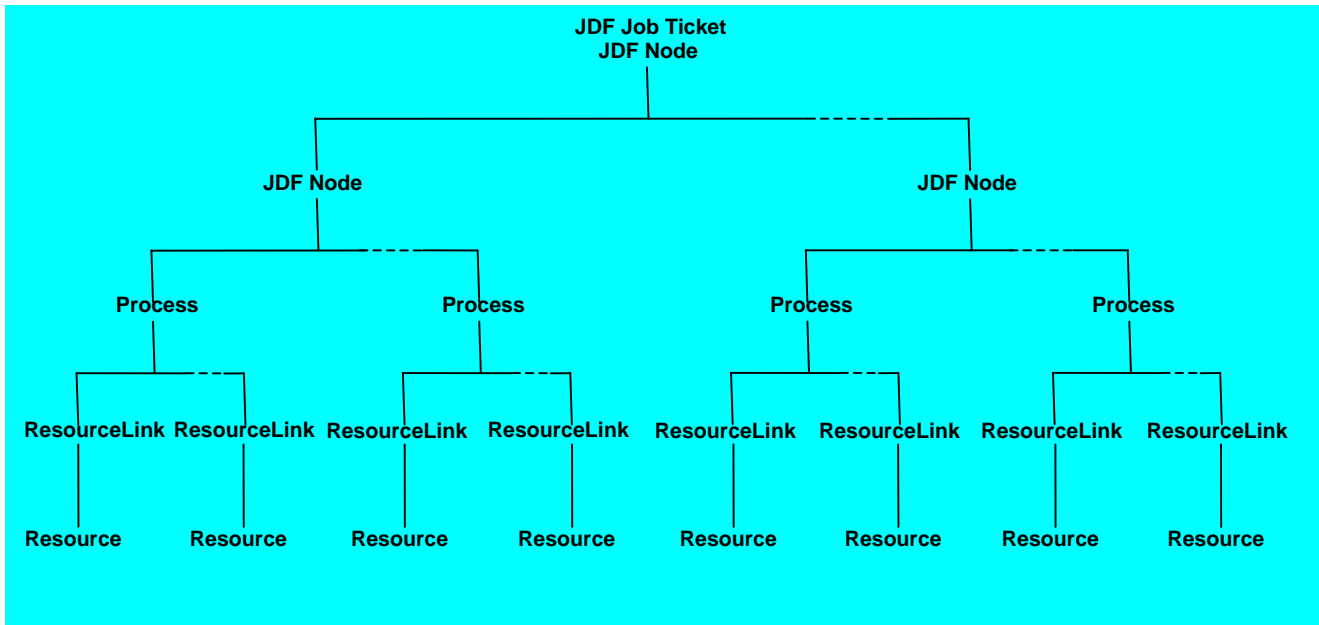

A JDF node is an XML element that represents an aspect of a job in terms of a process, such as stitching, folding, or trimming; in terms of a product that contributes to the end result, such as a brochure; or in terms of the combination of the two. A process is a unit of work or a step in the job workflow. A JDF node that is comprised of multiple processes is called a combined process JDF node.

Resources are inputs to and outputs from processes that provide details or information to the process or from one process to another process. For example, the `StitchingParams` resource is an input to the `Stitching` process and specifies the number of stitches and the placement of the stitches. The `Component` resource is an output of the `DigitalPrinting` process and specifies how many copies of the job to produce. The order that the processes are specified in a combined process JDF node is pertinent because it defines the order that the processes are to be executed. So if the job is to be stitched before it is folded as in the case of a saddle stitched booklet, then the `Stitching` process must be specified before the `Folding` process.

Figure 1-3 Process and Resource Relationship

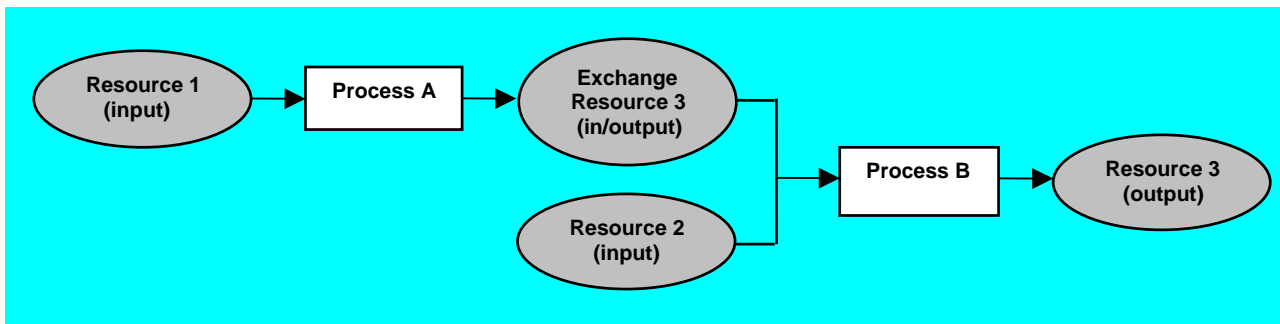

A JDF job ticket is an XML document so it requires that the version of XML and the character set encoding be specified.

```
<?xml version="1.0" encoding="UTF-8"?>
```

The attribute `encoding="UTF-8"` is the default that specifies compressed Unicode which includes ASCII as a subset.

A JDF node is specified as follows:

```
<JDF ID="node ID" Type="pre-defined JDF type or any JDF process" Types="list of JDF processes if combined process JDF node" Status="Ready" Activation="Active" xmlns="http://www.cip4.org/JDFSchema_1_1" xmlns:privatens="private XML namespace" Version="1.2">
```

JDF extensibility is implemented using XML namespaces. The URI for the official JDF XML namespace is http://www.cip4.org/JDFSchema_1_1. Private namespaces can be declared and used to extend existing JDF resources by adding private attributes and elements. The namespaces that are to be used by the job ticket are declared in the JDF node and appear as `xmlns:privatens="private namespace"`. Namespaces that contain vendor specific attributes and/or values can be declared.

The version of JDF that is used to generate the job ticket is specified in the outside JDF node by the Version attribute. The version of JDF that is supported by the Integrated Digital Printing ICS is 1.2.

A JDF node contains attributes and elements. Elements contain attributes and subelements. Subelements are XML elements that are contained in another element. A JDF node can contain any or all of the following elements:

- **Comment** - Human readable comment or description of the job ticket. A JDF node can contain 0 or more Comment elements.
- **AncestorPool** - Contains 1 or more Ancestor elements and is only required for a spawned job. Spawning is the process of extracting a JDF sub-node from a job and creating a new, complete JDF document. An Ancestor element reflects the family tree of the spawned job. A JDF node can contain 0 or 1 AncestorPool elements.
- **CustomerInfo** - Information about the customer who ordered the job. A JDF node can contain 0 or 1 CustomerInfo elements.
- **NodeInfo** - Information about planned scheduling and message routing. A JDF node can contain 0 or 1 NodeInfo elements.
- **ResourceLinkPool** - Links the JDF node to the Resources it uses. Also identifies the processes each Resource is an input to or output from and whether the Resource is an input or output. A JDF node can contain 0 or 1 ResourceLinkPool elements.
- **ResourcePool** - Contains 0 or more Resource elements where a Resource element is something that is consumed or produced. There are many possible Resources defined by JDF, many of which will not be supported by a specific implementation of JDF. A JDF node can contain 0 or 1 ResourcePool elements.
- **AuditPool** - Contains post-facto recorded results. A JDF node can contain 0 or 1 Audit Pool elements.
- **StatusPool** - Describes the status of a JDF node that processes partitioned Resources. A partitioned Resource is a Resource that has individual nested parts. A JDF node can contain 0 or 1 StatusPool elements.
- **JDF** - A nested JDF node. A JDF node can contain 0 or more JDF nodes.

1.2.3 Structure and Content of a JDF Job Ticket

The actual view of a JDF job ticket is the physical structure or content of the job ticket. Following is a sample JDF job ticket document that contains all of the elements described in the previous section:

Figure 1-4 Structure of a JDF Job Ticket

```
<?xml version="1.0" encoding="UTF-8"?>
<JDF ID="outer node ID" Type="pre-defined JDF type or any JDF process"
Types="list of JDF processes if combined process JDF node" Status="Ready" Activation="Active"
xmlns="http://www.cip4.org/JDFSchema_1_1" xmlns:privatens="private XML namespace" Version="1.2" ... >
```

```

<Comment ...>
</Comment>
<AncestorPool >
    <Ancestor .../>
    <Ancestor .../>
</AncestorPool>
<CustomerInfo .../>
<NodeInfo .../>
<ResourceLinkPool>
    <Link for 1st Resource and processes that use it appear here />
    <Link for 2nd Resource and processes that use it appear here />
</ResourceLinkPool>
<ResourcePool>
    <1st Resource appears here />
    <2nd Resource appears here />
</ResourcePool>
<AuditPool>
    <An Audit element appears here />
</AuditPool>
<StatusPool>
    <Status="Ready"/>
</StatusPool>
<JDF ID="inner node ID" Type="pre-defined JDF type or any JDF process"
Types="list of JDF processes in combined process JDF node" Status="Ready">
    Elements contained in this nested JDF node appear here. Any of the elements shown above in the outside
    JDF node can appear here.
</JDF>
</JDF>

```

Comments in a JDF Job Ticket

There are two types of comments that can appear in a JDF job ticket:

The following notation allows comments to be added inside of the job ticket. These comments aren't available outside of the job ticket. They are just comments to assist anyone reading the JDF in the job ticket.

```
<!-- The following specifies how to print duplex. -->
```

The following is a comment that can be extracted from the JDF job ticket and interpreted by the consumer of the job ticket:

```
<Comment Name="Description" A description of this job. </Comment>
```

1.3 Digital Printing Job Ticket

A Digital Printing Job Ticket MUST contain a combined process JDF node (Types="Combined") that contains some of the features described in section 3.2 Features Supported. The job ticket MAY contain JDF that is not described in this application note. In this case if a Device consuming the job ticket is only interested in the features included in this application note, then the Device MUST search for the combined process JDF node and process it.

For a Device to be in conformance with the Integrated Digital Printing ICS, it must be able to consume and process all of the JDF that appears in the Integrated Digital Printing ICS for a given conformance level without an error.

1.4 Conformance Interface, Producer, and Consumer

The following diagram, derived from the diagram that appears in the JDF Specification [JDF] section 2.1.2.6 System Interaction, shows the hierarchical structure and the interaction of the components in a JDF system.

Figure 1-5 Example of JDF and JMF workflow interactions

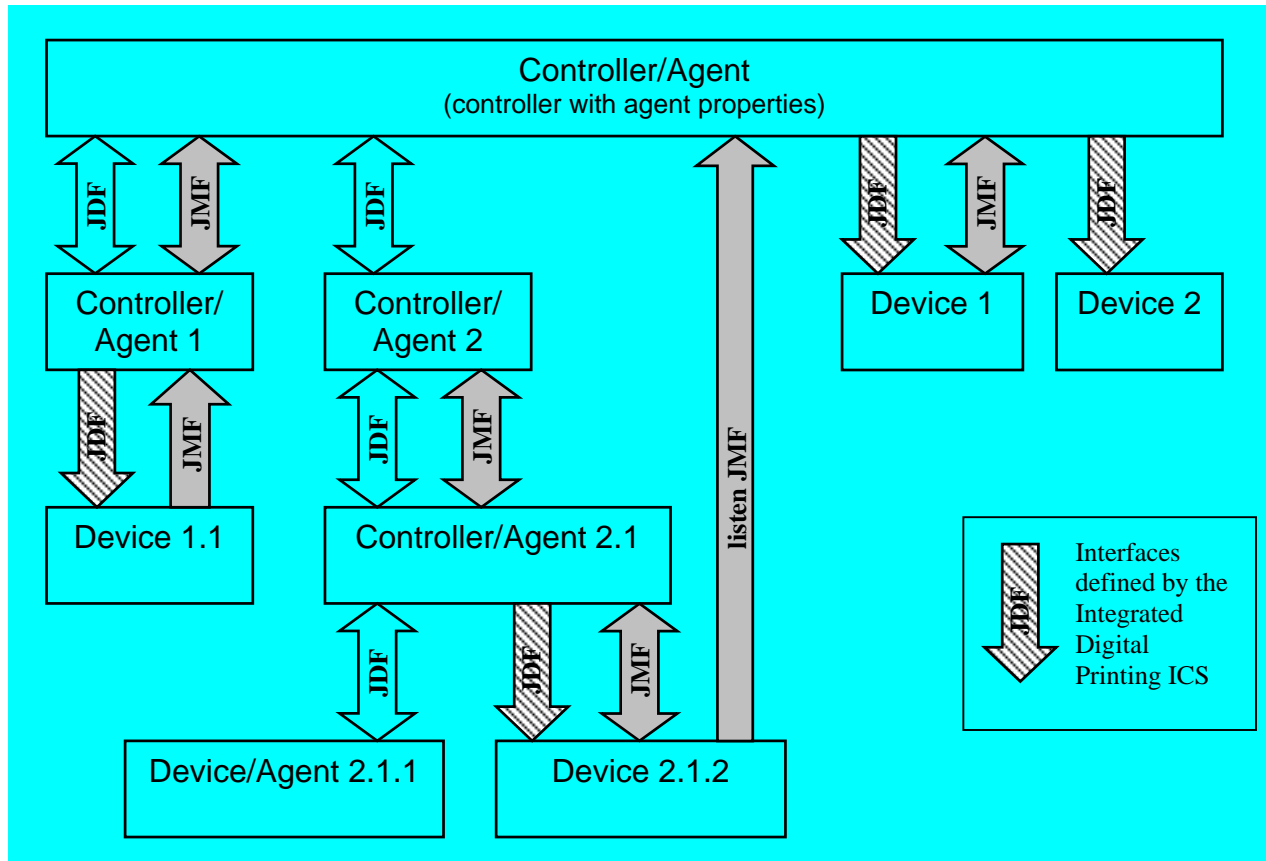

The diagram was modified to show the interfaces that are conformance interfaces for the Integrated Digital Printing ICS. These interfaces are shown by the arrows labeled "JDF" that have been cross-hatched. Note that all of the interfaces that are conformance interfaces for the Integrated Digital Printing ICS are interfaces in which a JDF instance is passed from the output of a Controller/Agent to the input to a Device.

The Conformance Interface defined in this application note consists of the interface between a Controller/Agent that produces a JDF instance and a Device that consumes a JDF instance and that executes a JDF *Combined* process that includes a DigitalPrinting process as specified by that JDF instance.

A Producer of this Interface is a Controller/Agent that uses a JDF instance to specify the execution of a JDF *Combined* process that includes a DigitalPrinting process by a Device.

A Consumer of this Interface is a Device that consumes JDF instances and that executes a JDF *Combined* process that includes a DigitalPrinting process as specified by that JDF instance.

1.5 Scope

This ICS defines a subset of JDF referred to as Level 1. Level 1 is useful for color and black and white integrated digital printing systems with in-line finishing capabilities. It encompasses production printing IPP semantics.

This application note includes the following:

- A combined process node that includes the DigitalPrinting process.

This application note does not specify conformance for or restrict any of the following:

- Product Intent, JMF, and Capabilities because they will be included in a future version or covered by another ICS.
- The Device is not required to write or add to a JDF job ticket (it is not an Agent). This includes AuditPool entries and StatusDetails.
- Job submission methods.
- Support for color will be added in a future version.

2 Terminology

A **job** is a unit of work that can be considered, at least from some point of view, by itself. Thus what is considered as a job from the point of view of a printing system may be a part of a job from the point of view of a print shop. JDF is concerned with specifying the unit of work that comprises a job and how it is to be accomplished via one or more steps. Typically, a job consists of work done on one or more files, using a set of resources, to produce output.

- 1) A **document** is a meaningful unit of information. It may be represented in various ways: for example as a file, as a part of a file, or by printed output from a job. The JDF defined in this specification specifies how input files are processed to produce output.
- 2) A **JDF job ticket** is a data structure that specifies how a job is to be done. A JDF job ticket is comprised of one or more **JDF nodes**. Each JDF node specifies a step in the performance of the job. A JDF node is represented by an XML element, and as such may have attributes and may contain subelements. Subelements are XML elements that are contained in another element.
- 3) A **process** is an entity that performs a unit of work or a step in the job workflow. Stitching processes, Folding processes, Trimming processes, and LayoutPreparation processes, are examples of processes. A JDF node specifies the unit of work done by one or more processes.

In addition to JDF nodes that specify the unit of work done by a single process, JDF also allows nodes that specify a job step that includes work done by two or more distinct processes. In this case the output resource(s) of one processes are the input resource(s) to another process. Such JDF nodes are called combined process nodes.

- 4) **Resources** are objects, such as Media, that are input to or output by processes. Resources that are input to processes may be consumed by the process (e.g., Media for the DigitalPrinting process) or merely used by them (e.g. Media for the LayoutPreparation process).
- 5) A **page** is a unit of output that is normally imaged on a single contiguous area on the output medium. The page is normally the unit of output to which medium selection, imposition, and a variety of other output processing options are applied.
- 6) A **sheet** is a unit of a medium, typically a sheet of paper or an area on a continuous roll of roll-fed paper, on which output is printed. Sheets may be cut and/folded after printing. A sheet with no folds typically contains 1 or 2 finished pages; a brochure with one fold inside normally contains 4 finished pages.

2.1 Conformance Terminology

See [BASE-ICS].

2.2 Other Terminology

This Conformance Specifications defines the following additional terminology:

Combined Digital Printing Node - A JDF *Combined* node (value of the Types attribute is "Combined") that contains a DigitalPrinting process and that conforms to the requirements of this ICS.

Conformance Level (**Level** for short) - a set of **REQUIRED** and **OPTIONAL Features** of an **Interface** for a **Device** to support that provide a certain level of service. If an **Interface** has multiple **Conformance Levels**, each higher **Conformance Level** is a superset of all the lower levels.

Controller/Agent as defined by the JDF Specification [JDF] is a JDF Controller/Agent that writes and routes JDF, representing a job, to a **Device**.

Customer - a user who purchases a **Consumer** product or a **Controller/Agent** product from a **Vendor**. It is the Customer who is concerned about Interoperability between **Device** and **Controller/Agent** products of a particular **Interface**. Some conformance requirements of a **Controller/Agent** or **Device** include interactions between the **Controller/Agent** and the **Customer** or between the **Device** and the **Customer**. For example, in order for a **Vendor** to claim conformance to an ICS for a **Device**, a **Customer** MUST be able to configure a default natural language for the **Device** to use.

Device as defined in the JDF Specification [JDF] interprets JDF and executes instructions representing a job.

Feature - the parts of an **Interface** that a **Device** supports and that a **Controller/Agent** invokes in order to achieve some well-defined behavior. The semantics of the **Feature** is defined in the Interface standard with reference to [JDF]. Examples of **Features** of an (1) API, (2) a file format, or (3) a network protocol **Interface** are: (1) functions in an Application Programming Interface (API), (2) an element in an XML file, and (3) an operation or attribute in a network protocol such as JMF, respectively.

JDF Interoperability Conformance Specification (ICS) - a CIP4 approved document that defines one or more **Interfaces** and/or **Conformance Levels** between entities in the JDF Specification [JDF] and the conformance requirements for a **Controller/Agent** and a **Device** of that **Interface** such that conforming implementations will interoperate.

Level 1 Combined Digital Printing Node conforms to the requirements of the ICS for Digital Printing for Conformance Level 1.

Level 1 Controller/Agent conforms to the requirements of the ICS for Digital Printing for Conformance Level 1.

Level 1 Device conforms to the requirements of the ICS for Digital Printing for Conformance Level 1.

Support - a **Device** implementation **supports** a **Feature**, if the **Device** implementation responds to a request from a **Controller/Agent** for that **Feature** across the **Interface**. Such a response MUST be according to the semantics defined in the JDF and ICS specifications. Note: a **Device** MAY choose to disable a **Feature** in the **Device**, so that the **Device** implementation no longer **supports** the **Feature**, but that is a **Customer** choice, not a **Vendor** choice.

Vendor - a company or organization that produces a product that conforms to the **Interface** defined in an ICS as a **Controller/Agent** or as a **Device** of that **Interface**. Some conformance requirements of a **Controller/Agent** or **Device** include interactions between the **Vendor** and the **Customer**. For example, in order for a **Vendor** to claim conformance to this application note for a **Device**, a **Vendor** MUST state the **Conformance Levels** and **Conformance Modules** supported by the **Device** implementation in any claim of conformance to this application note.

3 JDF Supported by Integrated Digital Printing ICS

This application note specifies a subset of JDF that can be used to enable interoperability when used by a Controller/Agent to specify the execution of a Combined Digital Printing Node. For Level 1, this application note defines:

- the requirements for a JDF node to be a (conforming) Combined Digital Printing Node;
- the requirements for a JDF Device to be a (conforming) Digital Printing Device

In defining conformance for a Combined Digital Printing Node, this application note defines

- a) JDF that the Combined Digital Printing Node **MUST** contain;
- b) JDF that the Combined Digital Printing Node **MAY** optionally contain.

Any JDF node that contains JDF that is not in either a) or b) does not conform to this application note.

In defining conformance for Digital Printing Devices, this ICS defines the JDF that the Integrated Digital Printing Device must support. This JDF includes all of the JDF that must be contained in a Combined Digital Printing Node, and also includes additional JDF that may optionally be contained in a Combined Digital Printing Node.

3.1 Combined Digital Printing Node

A conforming Device **MUST** execute a Combined Digital Printing Node.

3.1.1 Settings Policy

A conforming Device **MUST** support the SettingsPolicy attribute (and the BestEffortExceptions, MustHonorExceptions, and OperatorInterventionExceptions attributes) as supplied for that node or inherited from any parent node. However, such support is only **REQUIRED** for processes, elements, attributes, and attribute values included in this ICS.

3.1.2 Conformance Levels

Conformance Level 1 as defined by this application note includes support for the features defined in 3.2 Features Supported. For Level 1, there are features that **MUST** (Required) be supplied by the Controller/Agent and **MUST** be supported by the Device and features that **MAY** (Optional) be supplied by the Controller/Agent and **MAY** be supported by the Device.

A Combined Digital Printing Node does not conform to this application note if the Combined Digital Printing Node contains features that are not in this application note for the conformance level identified by the ICSVersions attribute.

A Device that conforms to this application note **MAY** support features that are not in this application note for the conformance level identified by the ICSVersions attribute.

If a feature **MUST** be supported by a Device that conforms to this application note, then regardless of the values of the SettingsPolicy attributes, the Device **MUST** be able to consume and process the JDF that the feature contains.

3.1.3 Processes

A Combined Digital Printing Node **MUST** be a JDF *Combined* node as specified in [JDF].

3.1.3.1 Required Processes

A Combined Digital Printing Node **MUST** contain one and only one of each of the following processes:

3.1.3.5 Processes and Exchange Resources

Resources represent the “things” that are produced (output) or consumed (input) by processes. Exchange Resources are resources that are produced by one process and consumed by another process within a JDF *Combined Node*.

In a JDF *Combined Node* a Resource that is an output from one process and an input to another (an Exchange resource) does not appear in the JDF Job Ticket.

The following diagram shows the sequence of the processes in a Combined Digital Printing Node and the flow of the content data (Exchange Resources) from one process to the next.

Figure 3-1 Process and Resource Flow

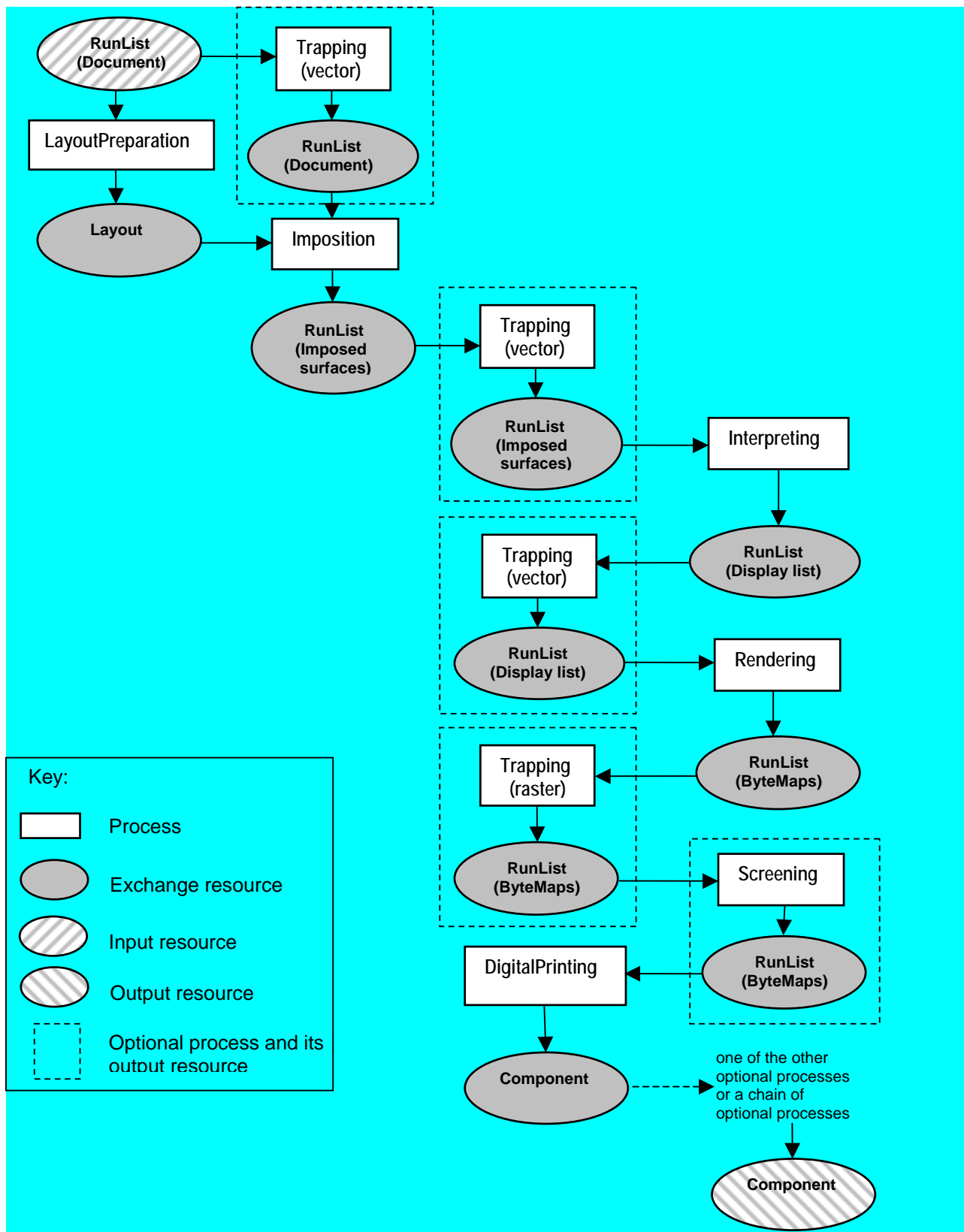

3.1.4 Combined Digital Printing Node Attributes

See Table 5 JDF (Combined Digital Printing Node for a list of the Combined Digital Printing Node attributes.

3.1.4.1 Types Attribute

The value of the *Types* attribute for the Combined Digital Printing Node consists of the sequence of *Type* values for the included processes.

The *Types* attribute of the Combined Digital Printing Node MUST contain the *Type* values for the required processes in 3.1.3.1 Required Processes. The *Type* values for each of the required processes MUST occur in the value of the *Types* attribute exactly once.

The *Type* values for each of the required processes MUST occur in the value of the *Types* attribute in the order in which the processes are listed in 3.1.3.1 Required Processes.

NOTE: For the Required processes the *Type* values that occur in the value of the *Types* attribute are:

1. "LayoutPreparation"
2. "Imposition"
3. "Interpreting"
4. "Rendering"
5. "DigitalPrinting"

The corresponding *Types* value for the above would be "LayoutPreparation Imposition Interpreting Rendering DigitalPrinting".

If a Trapping process is present, the Trapping process *Type* value MUST occur in the *Types* value.

The Trapping process *Type* value MAY appear in one of four places in the value of the *Types* attribute:

- a. before "Imposition" (for vector-based trapping)
- b. after "Imposition" (for vector-based trapping)
- c. after "Interpreting" (for vector-based trapping)
- d. after "Rendering" (for raster-based trapping)

The Trapping process *Type* value MUST NOT appear at any other place in the value of the *Types* attribute.

If a Screening process is present, the Screening process *Type* value MUST occur in the *Types* value.

For each of the processes listed in 3.1.3.2 Optional Finishing Processes that is present, the corresponding process:

- a. The *Type* value of the process MUST occur in the *Types* value
- b. The *Type* values must occur in the order in which the processes are executed
- c. The *Type* values MUST occur after the *Type* value of the DigitalPrinting process

3.1.5 Elements Included in a Combined Digital Printing Node

The following table lists the child elements of a Combined Digital Printing Node as specified in [JDF], and the number of occurrences of each that can occur in a Combined Digital Printing Node.

A Combined Digital Printing Node MUST contain exactly one of the child elements for which the number of occurrences specified is "1" and MAY contain "0 or 1" or "0 or more" of the other child elements, as specified in the following table.

Table 2 - Combined Digital Printing Node Child Elements and Number of Occurrences

JDF node child element	Number of occurrences
AuditPool	0 or 1
Comment	0 or more

CustomerInfo	0 or 1
NodeInfo	0 or 1
ResourcePool	1
ResourceLinkPool	1

3.1.6 Resources

The processes to be executed are defined in the Types attribute of the Combined Digital Printing Node. Resources are elements that are consumed (input) or produced (output) by processes. The Resources are defined and reside in the ResourcePool. The Resources are linked to their respective processes in the ResourceLinkPool.

3.1.6.1 Resource Attributes

A Resource that resides in the ResourcePool has a set of attributes. See Table 7 All Resources for a list of the Resource attributes.

3.1.6.2 Resources and Processes

The following table lists the input and output resources that are required by or optional for each of the processes included in a Combined Digital Printing Node.

Table 3 - Supported Processes and their Resources

Process	Required non-Exchange Input Resources	Optional non-Exchange Input Resources	Optional Intermediate Exchange Input Resources	Required non-Exchange Output Resources
Approval	ApprovalParams	---	---	Component ApprovalSuccess
CoverApplication	CoverApplicationParams	---	Component	Component (see * below)
DigitalPrinting	DigitalPrintingParams	ColorantControl Media	---	Component (see * below)
Folding	FoldingParams	---	Component	Component (see * below)
HoleMaking	HoleMakingParams	---	Component	Component (see * below)
Imposition	RunList (Document)	---	---	---
Interpreting	InterpretingParams	ColorantControl	---	---
LayoutPreparation	LayoutPreparationParams RunList (Document)	---	---	---
Rendering	RenderingParams (see ** below)	---	---	---
Screening	ScreeningParams	---	---	---
SpineTaping	SpineTapingParams	---	Component	Component (see * below)
Stitching	StitchingParams	---	Component	Component (see * below)
Trapping (raster)	TrappingDetails	ColorantControl	---	---
Trapping (vector)	TrappingDetails	ColorantControl	---	---
Trimming	TrimmingParams	---	---	Component (see * below)

* Component is a required output resource only if it occurs as the output resource of the last process listed in the Combined Digital Printing Node's Types attribute. Component is a non-Intermediate exchange resource for all other processes for which this note applies.

** The Integrated Digital Printing ICS requires that RenderingParams be provided as an input resource for the Rendering process. In [JDF] RenderingParams is not a required input resource to the Rendering process.

Because the LayoutPreparation, Imposition, Interpreting, Rendering, and DigitalPrinting processes MUST always be present in a Combined Digital Printing Node, the RunList and Component resources and their respective resource links MUST always be present as well.

Resources that are inputs to or outputs from processes MUST appear in the ResourcePool. There are also resources that appear in the ResourcePool that are not inputs to or outputs from processes, but are merely used by another resource that is in

the ResourcePool. The LayoutElement is an example of such a resource. It is defined in the ResourcePool and referenced by the RunList resource, but is not an input to or output from a process.

NOTE: Because LayoutElement is not an input to or output from a process, it does not have an associated resource link in the ResourceLinkPool.

3.1.6.3 Resources and ResourcePool

Resources required by the Combined Digital Printing node MUST be present in ResourcePool elements that are in the Combined Digital Printing node itself or ancestor nodes. Some types of Resources MUST only appear once in the ResourcePool, others MAY appear 0 or multiple times. The following table lists all possible resources and the number of times that they MUST or MAY appear in the ResourcePool.

Table 4 - Number of Occurrences of Supported Resources

Resource or Element	Number of occurrences
ApprovalParams	0 or 1
ColorantControl	0 or more
Component	1
CoverApplicationParams	0 or 1
Device	0 or 1
DigitalPrintingParams	1
FoldingParams	0 or 1
HoleMakingParams	0 or 1
InterpretingParams	1
LayoutElement	0 or more
LayoutPreparationParams	1
Media	0 or more
RenderingParams	1
RunList	1
ScreeningParams	0 or 1
SpineTapingParams	0 or 1
StitchingParams	0 or 1
TrappingDetails	0 or 1
TrimmingParams	0 or 1

3.1.6.4 ResourceLink elements and ResourceLinkPool

Each Combined Digital Printing node MUST contain a ResourceLinkPool element. A ResourceLink element for each Resource that is an input to or an output from a process MUST appear in the ResourceLinkPool. The ResourceLink elements also define whether the resources are inputs (consumed) or outputs (produced) and the processes they are inputs to or outputs from.

If a Resource is an input to a process, then the ResourceLink for the Resource MAY have a CombinedProcessIndex attribute. The CombinedProcessIndex attribute is an integer that is the zero-based index into the Combined Digital Printing Node's Types attribute. It identifies the processes that the resource is an input to. For example, as shown below, the CombinedProcessIndex for RunListLink MAY have a value of "0 1", because the RunList resource is an input to both the LayoutPreparation and Imposition processes.

```

...
<RunListLink rRef="RL" Usage="Input" CombinedProcessIndex="0 1" />
...
    
```

In most cases it is possible to unambiguously determine the process that a resource is an input to. In these cases it is not necessary to specify the CombinedProcessIndex.

- A CombinedProcessIndex is not required to (MAY) be specified for a ResourceLink under the following conditions:
 1. If a process requires an input Resource and one of its predecessor processes is able to provide an Intermediate ResourceLink, then the process MUST use that intermediate ResourceLink.

2. If a process requires an input Resource and none of the predecessor processes are able to provide an intermediate ResourceLink, then the process MUST be able to unambiguously determine which ResourceLink in the ResourceLinkPool to use.
3. If the input resource is an optional input to the process and it is not ambiguous as to which process the resource is an input to.
 - A CombinedProcessIndex MUST be specified for a ResourceLink under the following conditions:
 1. If the process requires an input Resource and it cannot unambiguously determine the required ResourceLink in the ResourceLinkPool to use.
 2. If the input Resource is an optional input to the process and it is ambiguous as to which process the resource is an input to..

If the CombinedProcessIndex is specified for a ResourceLink, then the process identified MUST use the Resource for that ResourceLink as the input resource even if a predecessor process provides an intermediate ResourceLink.

If there is a ComponentLink with the Usage attribute set to "Output" and the CombinedProcessIndex attribute is not present, then this ComponentLink is for a Component that is an output resource of the last process in the Combined Digital Printing Node.

The rRef attribute of each ResourceLink element references a Resource that is defined in the ResourcePool.

In the following example, the ComponentLink element is located in the ResourceLinkPool and uses the rRef attribute to reference the Component resource that is defined in the ResourcePool and has an ID of "Amount".

```

...
<ResourceLinkPool>
  <ComponentLink rRef="Amount" Usage="Output" Amount="5" />
  ...
</ResourceLinkPool>
<ResourcePool>
  <Component ID="Amount" Class="Quantity" Status="Unavailable"
    ComponentType="FinalProduct" />
  ...
</ResourcePool>
...

```

Only those Resources that appear in the ResourceLinkPool MUST be used when the job is processed. So if there are Resources defined in the ResourcePool that should be inputs to or outputs from the processes specified in the Types attribute for the JDF node, these Resources must each have a ResourceLink in the ResourceLinkPool or they will not be used.

In Figure 3-2 Structure of a Digital Printing Job Ticket there is a list of all possible ResourceLink elements that can exist in the ResourceLinkPool supported by the Integrated Digital Printing ICS. It is possible that some of the processes supported by the Integrated Digital Printing ICS may not be included in the job ticket because the function is not necessary or are not supported by the product, so the Resources required by that process will not be defined in the ResourcePool, and the ResourceLink for that Resource MUST not appear in the ResourceLinkPool. For example, if the job is not to be stitched, the Stitching process is not needed. "Stitching" MUST not appear in the Types attribute of the JDF node, there MUST not be a StitchingParams resource, and a StitchingParamsLink MUST not appear in the ResourceLinkPool.

A ResourceLink element with the Usage attribute set to "Intermediate" ISSUE: Tom: (and Resource/@Status = "Complete") and the Orientation attribute set to the desired rotation is used in a Combined Digital Printing node to change the orientation of a physical resource. ComponentLink is the only intermediate ResourceLink element that is supported in this application note. Specifying the Orientation attribute for ComponentLink causes the orientation of the media to be changed prior to execution of the process that the ComponentLink is an input to.

Following is an example of an intermediate ComponentLink that specifies that stitching is to occur in the upper right corner of the sheets. The left reference edge is the default if an intermediate ComponentLink with the Orientation attribute is not

specified for a process. In the following example the Orientation attribute is set to Rotate90 so that the sheets will be rotated 90 degrees counterclockwise before the Stitching process is executed.

```

...
<JDF ID="J1" Type="Combined" Types="LayoutPreparation Imposition Trapping Interpreting Rendering
  Screening DigitalPrinting Stitching Folding Trimming HoleMaking CoverApplication SpineTaping
  Approval" ... >
...
  <ResourceLinkPool>
    ...
    <ComponentLink rRef="StitchingOrientation" Usage="Output"
      PipeProtocol="Internal" PipeID="P1" CombinedProcessIndex="6" />
    <ComponentLink rRef="StitchingOrientation" Usage="Input"
      PipeProtocol="Internal" PipeID="P1" CombinedProcessIndex="7"
      Orientation="Rotate90" />
    <StitchingParamsLink rRef="StitchingParams" Usage="Input"
      CombinedProcessIndex="7" />
    ...
  </ResourceLinkPool>
  <ResourcePool>
    ...
    <Component ID="StitchingOrientation" ComponentType="PartialProduct" Status="Complete"/>
    <StitchingParams ID="StitchingParams" Class="Parameter" Status="Available"
      StitchType="Corner" NumberOfStitches="1" Angle="0" />
    ...
  </ResourcePool>
...
</JDF>

```

3.1.7 Structure and Content of a Digital Printing JDF Job Ticket

The structure and the content of a Digital Printing Job Ticket is shown as follows. The specific order of the elements belonging to a Combined Digital Printing Node, the resources listed in the ResourcePool, and the resource links in the ResourceLinkPool is not required by JDF. Only a subset of JDF processes and JDF resources as defined in this application note are supported in a Combined Digital Printing Node, all of which are listed below. Although all of the processes and resources that are supported by the Combined Digital Printing Node are listed below, it is unlikely that any one job ticket will contain all of them.

ISSUE: Should all JDF examples/snippets be in a different font?

Figure 3-2 Structure of a Digital Printing Job Ticket

```

<?xml version="1.0" encoding="UTF-8" standalone="yes" ?>
<JDF ID="J1" Category="DigitalPrinting" Type="Combined" Types="LayoutPreparation Imposition Trapping
  Interpreting Rendering Screening DigitalPrinting Stitching Folding Trimming HoleMaking
  CoverApplication SpineTaping Approval" Status="Ready" Activation="Active"
  xmlns="http://www.cip4.org/JDFSchema_1_1" xmlns:privatens="private XML namespace"
  Version="1.2" ... >
  <Comment ...>
  </Comment>
  <CustomerInfo ... />
  <NodeInfo ... />
  <ResourceLinkPool>
    <RunListLink rRef="ID of RunList resource" ...
      Usage="Input"

```



```

        CombinedProcessIndex="index into Types for LayoutPreparation and
        Imposition" />
<LayoutPreparationParamsLink rRef="ID of LayoutPreparationParams resource" ...
    Usage="Input"
    CombinedProcessIndex="index into Types for LayoutPreparation" />
<TrappingDetailsLink rRef="ID of TrappingDetails resource" ...
    Usage="Input"
    CombinedProcessIndex="index into Types for Trapping" />
<ColorantControlLink rRef="ID of ColorantControl resource" ...
    Usage="Input"
    CombinedProcessIndex="index into Types for Trapping, Interpreting, and/or
    DigitalPrinting" />
... additional ColorantControlLink elements
<InterpretingParamsLink rRef="ID of InterpretingParams resource" ...
    Usage="Input"
    CombinedProcessIndex="index into Types for Interpreting" />
<RenderingParamsLink rRef="ID of RenderingParams resource" ...
    Usage="Input"
    CombinedProcessIndex="index into Types for Rendering" />
<ScreeningParamsLink rRef="ID of ScreeningParams resource" ...
    Usage="Input"
    CombinedProcessIndex="index into Types for Screening" />
<ComponentLink rRef="ID of Component resource" ...
    Usage="Output" />
<DeviceLink rRef="ID of Device resource" ...
    Usage="Input" />
<MediaLink rRef="ID of Media resource" ...
    Usage="Input"
    CombinedProcessIndex="index into Types for DigitalPrinting" />
... additional MediaLink elements
<DigitalPrintingParamsLink rRef="ID of DigitalPrintingParams resource" ...
    Usage="Input"
    CombinedProcessIndex="index into Types for DigitalPrinting"/>
<ComponentLink rRef="ID of Component resource"
    Orientation="transformation of the orientation" ...
    Usage="Intermediate"
    CombinedProcessIndex="index into Types for Stitching process" />
<StitchingParamsLink rRef="ID of StitchingParams resource" ...
    Usage="Input"
    CombinedProcessIndex="index into Types for Stitching" />
<ComponentLink rRef="ID of Component resource"
    Orientation="transformation of the orientation" ...
    Usage="Intermediate"
    CombinedProcessIndex="index into Types for Folding process" />
<FoldingParamsLink rRef="ID of FoldingParams resource" ...
    Usage="Input"
    CombinedProcessIndex="index into Types for Folding" />
<TrimmingParamsLink rRef="ID of TrimmingParams resource" ...
    Usage="Input"
    CombinedProcessIndex="index into Types for Trimming" />
<ComponentLink rRef="ID of Component resource"
    Orientation="transformation of the orientation" ...
    Usage="Intermediate"
    CombinedProcessIndex="index into Types for HoleMaking process" />
<HoleMakingParamsLink rRef="ID of HoleMakingParams resource" ...
    Usage="Input"

```

```

        CombinedProcessIndex="index into Types for HoleMaking" />
    <ComponentLink rRef="ID of Component resource"
        Orientation="transformation of the orientation" ...
        Usage="Intermediate"
        CombinedProcessIndex="index into Types for CoverApplication process" />
    <CoverApplicationParamsLink rRef="ID of CoverApplicationParams resource" ...
        Usage="Input"
        CombinedProcessIndex="index into Types for CoverApplication" />
    <ComponentLink rRef="ID of Component resource"
        Orientation="transformation of the orientation" ...
        Usage="Intermediate"
        CombinedProcessIndex="index into Types for SpineTaping process" />
    <SpineTapingParamsLink rRef="ID of SpineTapingParams resource" ...
        Usage="Input"
        CombinedProcessIndex="index into Types for SpineTaping" />
    <ApprovalParamsLink rRef="ID of ApprovalParams resource" ...
        Usage="Input"
        CombinedProcessIndex="index into Types for Approval" />
    <ApprovalSuccessLink rRef="ID of ApprovalSuccess resource" ...
        Usage="Output"
        CombinedProcessIndex="index into Types for Approval" />
</ResourceLinkPool>
<ResourcePool>
    <LayoutElement ... />
    ... additional LayoutElement resources
    <RunList ... >
        <LayoutElementRef ... />
    </RunList>
    <LayoutPreparationParams ...
    />
    <TrappingDetails ... />
    <ColorantControl .../>
    ... additional ColorantControl resources
    <InterpretingParams.../>
    <RenderingParams .../>
    <ScreeningParams ... />
    <Component ... />
    <Device ... />
    <Media ... />
    ... additional Media resources
    <DigitalPrintingParams ... >
        <MediaRef ... />
    </DigitalPrintingParams>
    <Component .../>
    <StitchingParams ... />
    <Component .../>
    <FoldingParams ... />
    <TrimmingParams ... />
    <Component .../>
    <HoleMakingParams ... />
    <Component .../>
    <CoverApplicationParams ... />
    <Component .../>
    <SpineTapingParams ... />
    <ApprovalParams ... />
    <ApprovalSuccess ... />

```

```

    </ResourcePool>
    <AuditPool>
      <Created ... />
      <Modified ... />
      ... additional Modified elements
    </AuditPool>
  </JDF>

```

The processes listed above as the values for the JDF node’s Types attribute are the processes that MUST be executed. If the work performed by a process is not to be performed, the process MUST not appear as a value for the Types attribute and resources MUST not be defined in the ResourcePool or ResourceLinkPool for that process. For example, if the job is not to be stitched, the Stitching process MUST not appear as a value for Types, and StitchingParams MUST not appear in the ResourcePool or StitchingParamsLink in the ResourceLinkPool.

The order of the processes listed in the JDF node’s Types attribute is significant because it is the order that the processes MUST be executed, which is the order that the work will be performed (for example, Stitching MUST occur before Folding as shown above). The order is not significant for commutative processes. Commutative processes when executed produce the same result regardless of the order in which the processes are executed. For example, if the Types attribute contains HoleMaking and Stitching and the result is the same as if Stitching is listed before HoleMaking, then the Device can execute the Stitching process before the HoleMaking process.

Vector Trapping is an example of a process that can be executed in one of multiple places. If the Device is only able to perform the vector Trapping process in one place and the result is the same as if the Trapping process were specified in another place, then the device is free to perform vector trapping in an order other than what is specified in the Types attribute.

In a Combined Digital Printing Node the output resource of one process can be the input resource to another process; this type of resource is called an exchange resource. It is important to note that when a resource is an exchange resource, a corresponding resource link MUST not appear in the ResourceLinkPool, unless the resource link is a link for an intermediate exchange resource. A link for an intermediate exchange resource MUST be present in the ResourceLinkPool when it is necessary to specify information that can only be specified in the link for the exchange resource (Orientation for example). The Usage attribute of the link for an intermediate exchange resource MUST be set to "Intermediate". A resource link for a resource that is not an exchange resource MUST appear in the ResourceLinkPool if the processes that it is an input to or output from are listed in the JDF node’s Types attribute.

3.1.8 JDF Conformance Tables for Integrated Digital Printing ICS

The following tables summarize the JDF resources and elements that are supported by the Integrated Digital Printing ICS. The tables follow the format as defined in the [BASE-ICS] for JDF Conformance Tables, except in the following cases:

1. Another column has been added that identifies the Feature(s) that are defined in the [DP-AppNote] that use the resource or element. This information is informative.
2. In the [BASE-ICS] column 5 is titled "Controller". In the Integrated Digital Printing ICS the corresponding column is "Controller/Agent".
3. The processes that use a particular element or resource are listed under "**Processes where used**" for each table.

Table 5 JDF (Combined Digital Printing Node)

- Processes where used:
 - N/A

Item	Attribute (@) or Element	Notes	Data Type or Value (D=Default value)	Contr	Devic	Features where used
				oller/ Agent	e	
				Level 1	Level 1	

Item	Attribute (@) or Element	Notes	Data Type or Value (D=Default value)	Contr	Devic	Features where used
				oller/ Agent Level 1	e Level 1	
1	JDF/		element	W	R	All
2	@Activation ?		enumeration	W	R	Hold Job
3			Active	W	R	same as above
4			Held	W	R	same as above
5	@Category ?		NMTOKEN	W	R	All
6		Must be present.	DigitalPrinting	W	R	All
7	@DescriptiveName		string	W*	R	Job Name
8	@ICSVersions ?		NMTOKENS	W	R	ICS Versions
9		One or more MUST be present	DP_L1-1.0	W	R	ICS Versions
10	@ID		ID	W	R	All
11	@JobID ?	If not present in the Combined Digital Printing Node, is inherited from an ancestor node.	ID	W*	R	Job Identification
12	@JobPartID ?		ID	W?	R?	Job Identification
13	@NamedFeatures ?		NMTOKENS	W?	R?	Named Features
14	@ProjectID ?		string	W?	R?	MIS Support
15	@RelatedJobID ?		string	W?	R?	Job Identification
16	@RelatedJobPartID ?		string	W?	R?	Job Identification
17	@SpawnID ?		NMTOKEN	W?	R?	Job Identification
18	@TemplateID ?		string	W*	R?	Job Ticket Template ID
19	@TemplateVersion ?		string	W*	R?	Job Ticket Template Version
20	@Type		NMTOKEN	W	R	All
21			Combined	W	R	All
22	@Types?	See Table 1 - Possible successor processes of each predecessor process for the order of the values.	NMTOKENS	W	R	All
23			LayoutPreparation	W	R	Many
24			Imposition	W	R	All
25			Interpreting	W	R	Print Quality
26			Rendering	W	R	Approval Destination or Physical Printer Resolution Proof Print
27			DigitalPrinting	W	R	Many
28			CoverApplication	W*	R?	Binding
29			Folding	W*	R?	Folding
30			HoleMaking	W*	R?	Punching and Hole Making
31			Stitching	W*	R?	Stapling and Stitching
32			SpineTaping	W*	R?	Binding
33			Trimming	W*	R?	Trimming
34			Approval	W*	R?	Approval
35			Screening	W*	R?	Screening
36			Trapping	W*	R?	Trapping
37	@SettingsPolicy ?		enumeration	W*	R?	Settings Policy
38		This is the Default, but its NOT a Schema default.	BestEffort	W*	R	Settings Policy
39			MustHonor	W*	R	Settings Policy
40			OperatorIntervention	W*	R	Settings Policy
41	@Status		enumeration	W	R	All
42			Ready	W	R	All

Item	Attribute (@) or Element	Notes	Data Type or Value (D=Default value)	Contr	Devic	Features where used
				oller/ Agent	e	
				Level 1	Level 1	
43	@Version ?	MUST be present in both JDF root node. and Combined Digital Printing Node.	string	W	R	All
44			1.2	W	R	All
45	@xmlns ?	MUST be present in JDF root node.	URI	W	R	All
46			http://www.cip4.org/JDFSchema_1_1	W	R	All
47	AuditPool ?	MUST be present and local, is not inherited from an ancestor node.	element	W	R	Job Created By Job Modified By Job Ticket Created By
48	Comment *		element	W*	R	Job Ticket Template Comment or Description
49	CustomerInfo?	If not present in the Combined Digital Printing Node, is inherited from an ancestor node.	element	W*	R	Billing Code Contact Information Job Name Notification
50	NodeInfo ?	If present, MUST be local. Is not inherited from an ancestor node.	element	W*	R	Job Priority Destination or Physical Printer Requested
51	ResourcePool	MUST be present in Combined Digital Printing Node and/or an ancestors' node.	element	W	R	All
52	ResourceLinkPool	MUST be present and local, is not inherited from an ancestor node.	element	W	R	All

Table 6 All Elements (except Combined Digital Printing Node)

- Processes where used:
 - Process for which element is specified

Item	Attribute (@) or Element	Notes	Data Type or Value (D=Default value)	Contr	Devic	Features where used
				oller/ Agent	e	
				Level 1	Level 1	
1	JDF/ <i>Element name/</i>		element	W	R	All
2	@BestEffortExceptions ?		NMTOKEN <i>where values are attribute names</i>	W*	R?	Settings Policy
3	@ID		ID	W	R	All
4	@MustHonorExceptions ?		NMTOKEN <i>where values are attribute names</i>	W*	R?	same as above
5	@OperatorInterventionExceptions ?		NMTOKEN <i>where values are attribute names</i>	W*	R?	same as above
6	@SettingsPolicy ?		enumeration	W*	R?	same as above
7		This is the Default, but its NOT a Schema default	BestEffort	W*	R	same as above
8			MustHonor	W*	R	same as above
9			OperatorIntervention	W*	R	same as above

Table 7 All Resources

- Processes where used:
 - Process for which resource is specified

Item	Attribute (@) or Element	Notes	Data Type or Value (D=Default value)	Contr	Devic	Features where used	
				oller/ Agent	e		
				Level 1	Level 1		
1	//JDF/ ResourcePool/ Resource name/		element	W	R	All	
2	@Class		enumeration	W	R	All	
3			Consumable	W	R	All	
4			Implementation	W	R	All	
5			Parameter	W	R	All	
6			Quantity	W	R	All	
7	@Status		enumeration	W	R	All	
8		Valid value for input and output resources other than Physical Resources	Complete	W	R	All	
9		Valid value for input Resources	Available	W	R	All	
10		Valid value for output Resources	Unavailable	W	R	All	

Table 8 All ResourceLink elements

- Processes where used:
 - Process for which resource link is specified

Item	Attribute (@) or Element	Notes	Data Type or Value (D=Default value)	Contr	Devic	Features where used	
				oller/ Agent	e		
				Level 1	Level 1		
1	JDF/ ResourceLinkPool/ ResourceLink name/		element	W	R	All	
2	@CombinedProcessIndex ?	See Application Note ResourceLink elements and ResourceLinkPool on page 22 for a description of when to specify CombinedProcessIndex.	IntegerList	W*	R	All	
3	@rRef		IDREF	W	R	All	
4	@Usage		enumeration	W	R	All	
5			Input	W	R	All	
6			Output	W	R	All	

Table 9 All ResourceRef elements

- Processes where used:
 - Process for which resource reference is specified

Item	Attribute (@) or Element	Notes	Data Type or Value (D=Default value)	Contr	Devic	Features where used	
				oller/ Agent	e		
				Level 1	Level 1		

Item	Attribute (@) or Element	Notes	Data Type or Value (D=Default value)	Contr	Devic	Features where used
				oller/ Agent Level 1	e Level 1	
1	JDF/ RunList/ ResourceRefName/		element	W	R	All
2	@rRef		ID	W	R	All

Table 10 Address

- Processes where used:
 - N/A

Item	Attribute (@) or Element	Notes	Data Type or Value (D=Default value)	Contr	Devic	Features where used
				oller/ Agent Level 1	e Level 1	
1	JDF/ CustomerInfo/ Contact/ Address/		element	W?	R?	Approval Contact Information Proof Print
2	@City ?		string	W?	R?	same as above
3	@Country ?		string	W?	R?	same as above
4	@ExtendedAddress ?		string	W?	R?	same as above
5	@PostalCode ?		string	W?	R?	same as above
6	@PostBox ?		string	W?	R?	same as above
7	@Region ?		string	W?	R?	same as above
8	@Street ?		string	W?	R?	same as above

Table 11 ApprovalParams

- Processes where used:
 - Approval
 - DigitalPrinting

Item	Attribute (@) or Element	Notes	Data Type or Value (D=Default value)	Contr	Devic	Features where used
				oller/ Agent Level 1	e Level 1	
1	JDF/ ResourcePool/ ApprovalParams/		element	W*	R	Approval
2	JDF/ ResourcePool/ DigitalPrintingParams/ ApprovalParams/		refelement	W*	R	Proof Print
3	ApprovalPerson *		element	W*	R	Approval Proof Print

Table 12 ApprovalPerson

- Processes where used:
 - Approval
 - DigitalPrinting

Item	Attribute (@) or Element	Notes	Data Type or Value (D=Default value)	Contr	Devic	Features where used
				oller/ Agent	e	
				Level 1	Level 1	
1	JDF/ ResourcePool/ ApprovalParams/ ApprovalPerson/		element	W*	R	Approval
2	JDF/ ResourcePool/ DigitalPrintingParams/ ApprovalParams/ ApprovalPerson/		element	W*	R	Proof Print
3	Contact		refelement	W	R	Approval Proof Print

Table 13 ApprovalSuccess

- Processes where used:
 - Approval

Item	Attribute (@) or Element	Notes	Data Type or Value (D=Default value)	Contr	Devic	Features where used
				oller/ Agent	e	
				Level 1	Level 1	
1	JDF/ ResourcePool/ ApprovalSuccess/	No attributes are supported	element	W*	R	Approval

Table 14 AuditPool

- Processes where used:
 - N/A

Item	Attribute (@) or Element	Notes	Data Type or Value (D=Default value)	Contr	Devic	Features where used
				oller/ Agent	e	
				Level 1	Level 1	
1	JDF/ AuditPool/		element	W	R	Job Created By Job Modified By Job Ticket Created By
2	Created *		element	W	R	Job Created By Job Ticket Created By
3	Modified *		element	W*	R	Job Modified By

Table 15 AutomatedOverPrintParams

- Processes where used:
 - Rendering

Item	Attribute (@) or Element	Notes	Data Type or Value (D=Default value)	Contr	Devic	Features where used
				oller/ Agent	e	
				Level 1	Level 1	
1	JDF/ ResourcePool/ RenderingParams/		refelement	W?	R?	Black Overprint

Item	Attribute (@) or Element	Notes	Data Type or Value (D=Default value)	Contr	Devic	Features where used
				oller/ Agent Level 1	e Level 1	
	AutomatedOverPrintParams/					
2	@OverPrintBlackLineArt ?		boolean	W?	R?	same as above
3			false (D)	W?	R?	same as above
4			true	W?	R?	same as above
5	@OverPrintBlackText ?		boolean	W?	R?	same as above
6			false (D)	W?	R?	same as above
7			true	W?	R?	same as above

Table 16 ColorantControl

- Processes where used:
 - DigitalPrinting
 - Interpreting

Item	Attribute (@) or Element	Notes	Data Type or Value (D=Default value)	Contr	Devic	Features where used
				oller/ Agent Level 1	e Level 1	
1	JDF/ResourcePool/ColorantControl/		element	W*	R	Process Color Model Spot Color
2	@PartIDKeys ?		enumerations	W*	R	same as above
3			DocIndex	W*	R	same as above
4			RunIndex	W*	R	same as above
5			DocIndex RunIndex	X	X	same as above
6		See Table 65 Partitioning Resources other than RunList for other PartIDKeys values.		W?	R?	same as above
7	@ProcessColorModel ?		NMTOKEN	W*	R	Process Color Model
8			DeviceCMYK	W*	R	same as above
9			DeviceGray	W*	R	same as above
10	ColorantParams ?		element	W*	R	Spot Color

Table 17 ColorantParams

- Processes where used:
 - Interpreting

Item	Attribute (@) or Element	Notes	Data Type or Value (D=Default value)	Contr	Devic	Features where used
				oller/ Agent Level 1	e Level 1	
1	JDF/ResourcePool/ColorantControl/ColorantParams/		element	W*	R	Spot Color
2	SeparationSpec *		refelement	W*	R	same as above

Table 18 ComChannel

- Processes where used:

- o N/A

Item	Attribute (@) or Element	Notes	Data Type or Value (D=Default value)	Controller/Agent	Device	Features where used
				Level 1	Level 1	
1	JDF/ CustomerInfo/ Contact/ ComChannel/		refelement	W?	R?	Contact Information
2	JDF/ ResourcePool/ ApprovalParams/ ApprovalPerson/ Contact/ ComChannel/		refelement	W?	R?	Approval
3	JDF/ ResourcePool/ DigitalPrintingParams/ ApprovalParams/ ApprovalPerson/ Contact/ ComChannel/		refelement	W?	R?	Proof Print
4	JDF/ CustomerInfo/ CustomerMessage/ ComChannel/		refelement	W?	R?	Notification
5	@ChannelType		enumeration	W?	R?	Approval Contact Information Proof Print Notification
4			Email	W?	R?	same as above
5			Fax	W?	R?	same as above
6			InstantMessaging	W?	R?	same as above
7			JMF	W?	R?	same as above
8			Phone	W?	R?	same as above
9			PrivateDirectory	W?	R?	same as above
10			WWW	W?	R?	same as above
11	@ChannelTypeDetails ?		NMTOKEN	W?	R?	same as above
12		Should this value be in this ICS?	Form	W?	R	same as above
13			ISDN	W?	R?	same as above
14			Landline	W?	R?	same as above
15			Mobile	W?	R?	same as above
16			Secure	W?	R?	same as above
17			Target	W?	R?	same as above
18	@Locator	MUST be in URL format	string	W?	R?	same as above

Table 19 Comment

- Processes where used:
 - o DigitalPrinting

Item	Attribute (@) or Element	Notes	Data Type or Value (D=Default value)	Controller/Agent	Device	Features where used
				Level 1	Level 1	
1	JDF/ ResourcePool/ Media/ Comment/		element	W?	R	Media
2	JDF/ Comment/		element	W?	R	Comment/Description of Job Job Ticket Template

Item	Attribute (@) or Element	Notes	Data Type or Value (D=Default value)	Contr	Devic	Features where used
				oller/ Agent	e	
				Level 1	Level 1	
						Comment or Description Message to Operator
3	@Language ?		language	W?	R	Comment/Description of Job Job Ticket Template Comment or Description Media Message to Operator
4	@Name ?		NMTOKEN	W?	R	Comment/Description of Job Job Ticket Template Comment or Description Media Message to Operator
5			Description (D)	W?	R	Media
6		If present, MUST appear in the root JDF Node.	JobDescription	W?	R	Comment/Description of Job
7			Instruction	W?	R	Message to Operator
8			TemplateDescription	W*	R?	Job Ticket Template Comment or Description
9	text		text	W	R	Comment/Description of Job Job Ticket Template Comment or Description Media Message to Operator

Table 20 Company

- Processes where used:
 - Approval
 - DigitalPrinting

Item	Attribute (@) or Element	Notes	Data Type or Value (D=Default value)	Contr	Devic	Features where used
				oller/ Agent	e	
				Level 1	Level 1	
1	JDF/ CustomerInfo/ Contact/ Company/		element	W?	R?	Approval Contact Information Proof Print
2	@OrganizationName		string	W?	R?	same as above

Table 21 Component

- Processes where used:
 - DigitalPrinting
 - Folding
 - HoleMaking
 - Stitching

Item	Attribute (@) or Element	Notes	Data Type or Value (D=Default value)	Contr	Devic	Features where used
				oller/ Agent	e	
				Level 1	Level 1	
1	JDF/ ResourcePool/ Component/		refelement	W	R	Number of Copies Binding Folding Punching and Hole Making

Item	Attribute (@) or Element	Notes	Data Type or Value (D=Default value)	Contr	Devic	Features where used
				oller/ Agent Level 1	e Level 1	
						Stapling and Stitching
2	@ComponentType		enumeration	W	R	All
3			FinalProduct	W	R	All
4			PartialProduct	W	R	Binding Folding Punching and Hole Making Stapling and Stitching
5	@ProductID ?		string	W*	R?	MIS Support
6	@Status		enumeration	W*	R	Binding Folding Punching and Hole Making Stapling and Stitching
		Needed only when changing Orientation on an exchange resource.	Complete	W	R	same as above

Table 22 ComponentLink

- Processes where used:
 - Binding
 - DigitalPrinting
 - Folding
 - HoleMaking
 - Stitching

Item	Attribute (@) or Element	Notes	Data Type or Value (D=Default value)	Contr	Devic	Features where used
				oller/ Agent Level 1	e Level 1	
1	JDF/ ResourceLinkPool/ ComponentLink/		element	W	R	Number of Copies Binding Folding Punching and Hole Making Stapling and Stitching
2	@Amount ?		integer	W	R	Number of Copies
3	@Orientation ?	Orientation is only valid when PipeProtocol="Internal"	enumeration	W*	R	Binding Folding Punching and Hole Making Stapling and Stitching
4			Rotate0	W*	R	same as above
5			Rotate90	W*	R	same as above
6			Rotate180	W*	R	same as above
7			Rotate270	W*	R	same as above
8			Flip0	W?	R?	same as above
9			Flip90	W?	R?	same as above
10			Flip180	W?	R?	same as above
11			Flip270	W?	R?	same as above
12	@PipeID		ID	W	R	same as above
13	@PipeProtocol		enumeration	W	R	same as above
14			Internal	W	R	same as above
15	@Usage		enumeration	W	R	Number of Copies
16			Output	W	R	Number of Copies

Table 23 Contact

- Processes where used:

- o Approval
- o DigitalPrinting

Item	Attribute (@) or Element	Notes	Data Type or Value (D=Default value)	Controller/Agent	Device	Features where used
				Level 1	Level 1	
1	JDF/ CustomerInfo/ Contact/		refelement	W?	R?	Contact Information
2	JDF/ResourcePool/Digital PrintingParams/ApprovalParams/ ApprovalPerson/Contact/		refelement			Proof Print
3	JDF/ResourcePool/ApprovalParams/ApprovalPerson/Contact/		refelement			Approval
4	@ContactTypes		NMTOKEN	W	R	Approval Contact Information Proof Print
5	Address ?		refelement	W?	R?	Approval Contact Information Proof Print
6	ComChannel *		refelement	W?	R?	Approval Contact Information Proof Print
7	Company ?		refelement	W?	R?	Approval Contact Information Proof Print
8	Person ?		refelement	W?	R?	Approval Contact Information Proof Print

Table 24 CoverApplicationParams

- Processes where used:
 - o CoverApplication

Item	Attribute (@) or Element	Notes	Data Type or Value (D=Default value)	Controller/Agent	Device	Features where used
				Level 1	Level 1	
1	JDF/ ResourcePool/ CoverApplicationParams/		element	W*	R?	Binding
2	@NoOp ?		boolean	W	R	same as above
3			false (D)	W	R	same as above
4			true	W	R	same as above
5	@PartIDKeys ?		enumerations	W*	R	same as above
6			DocIndex	W*	R	same as above
7			RunIndex	W*	R	same as above
8			DocIndex RunIndex	X	X	same as above
9		See Table 65 Partitioning Resources other than RunList for other PartIDKeys values.		W?	R?	same as above

Table 25 CustomerInfo

- Processes where used:
 - o N/A

Item	Attribute (@) or Element	Notes	Data Type or Value (D=Default value)	Contr	Devic	Features where used
				oller/ Agent Level 1	e Level 1	
1	JDF/ CustomerInfo/		element	W	R	Billing Code Contact Information Job Name Notification
2	@BillingCode		string	W?	R?	Billing Code
3	@CustomerJobName		string	W	R	Job Name
4	Contact *		refelement	W?	R?	Contact Information
5	CustomerMessage *		element	W?	R?	Notification

Table 26 CustomerMessage

- Processes where used:
 - N/A

Item	Attribute (@) or Element	Notes	Data Type or Value (D=Default value)	Contr	Devic	Features where used
				oller/ Agent Level 1	e Level 1	
1	JDF/ CustomerInfo/ CustomerMessage		element	W?	R	Notification
2	@Language ?		string	W?	R?	same as above
3	@MessageEvents		NMTOKENS	W	R	same as above
4			Accepted	W?	R?	same as above
5			JobCompletedSucces sfully	W*	R	same as above
6			JobCompletedWithEr rors	W*	R	same as above
7			JobCompletedWithW arning	W*	R	same as above
8			JobInProgress	W?	R?	same as above
9	@ShowList ?		NMTOKENS	W?	R?	same as above
10			UserText	W?	R?	same as above
11	@UserText ?		string	W?	R?	same as above
12	ComChannel*		refelement	W?	R?	same as above

Table 27 Device

- Processes where used:
 - N/A

Item	Attribute (@) or Element	Notes	Data Type or Value (D=Default value)	Contr	Devic	Features where used
				oller/ Agent Level 1	e Level 1	
1	JDF/ ResourcePool/ Device/		element	W*	R	Destination or Physical Printer Requested
2	@DeviceID		string	W	R	same as above
3	@Manufacturer ?		string	W?	R?	same as above
4	@ModelNumber ?		string	W?	R?	same as above

Table 28 DigitalPrintingParams

- Processes where used:
 - DigitalPrinting

Item	Attribute (@) or Element	Notes	Data Type or Value (D=Default value)	Controller/Agent	Device	Features where used
				Level 1	Level 1	
1	JDF/ DigitalPrintingParams/		element	W	R	Collate Input Tray Name Jog Offset Margins Output Bin Name Page Delivery Proof Print
2	@Collate ?		enumeration	W*	R	Collate
3			None	W*	R	same as above
4			Sheet	W*	R	same as above
5			SheetAndSet	W?	R?	same as above
6			SheetSetAndJob	W?	R?	same as above
7	@DirectProofAmount ?		integer	W*	R?	Proof Print
8	@ManualFeed ?		boolean	W*	R	Input Tray Name
9			false (D)	W*	R	same as above
10			true	W*	R	same as above
11	@NonPrintableMarginBottom ?		double	W?	R?	Margins
12	@NonPrintableMarginLeft ?		double	W?	R?	Margins
13	@NonPrintableMarginRight ?		double	W?	R?	Margins
14	@NonPrintableMarginTop ?		double	W?	R?	Margins
15	@OutputBin ?		NMTOKEN	W*	R	Output Bin Name
16			AnyLargeFormat	W?	R?	same as above
17			AnySmallFormat	W?	R?	same as above
18			AutoSelect	W?	R?	same as above
19			Booklet	W?	R?	same as above
20			Bottom	W?	R?	same as above
21			Continuous	W?	R?	same as above
22			Disc	W?	R?	same as above
23			Disc-n	W?	R?	same as above
24			Envelope	W?	R?	same as above
25			Envelope-n	W?	R?	same as above
26			FaceDown	W?	R?	same as above
27			FaceUp	W?	R?	same as above
28			FitMedia	W?	R?	same as above
29			Front	W?	R?	same as above
30			LargeCapacity	W*	R	same as above
31			LargeCapacity-n	W?	R?	same as above
32			Left	W?	R?	same as above
33			Mailbox-n	W?	R?	same as above
34			Middle	W?	R?	same as above
35			MyMailbox	W?	R?	same as above
36			Rear	W?	R?	same as above
37			Right	W?	R?	same as above
38			Roll	W?	R?	same as above
39			Roll-n	W?	R?	same as above
40			Side	W?	R?	same as above
41			Stacker-n	W?	R?	same as above
42			Top	W*	R	same as above
43			Tray	W?	R?	same as above
44			Tray-n	W?	R?	same as above
45	@PageDelivery ?		enumeration	W?	R?	Page Delivery
46			Fanfold	W?	R?	same as above

Item	Attribute (@) or Element	Notes	Data Type or Value (D=Default value)	Contr	Devic	Features where used	
				oller/ Agent	e		
				Level 1	Level 1		
47			SameOrderFaceUp	W?	R?	same as above	
48			SameOrderFaceDown	W?	R?	same as above	
49			ReverseOrderFaceUp	W?	R?	same as above	
50			ReverseOrderFaceDown	W?	R?	same as above	
51	@PartIDKeys ?		enumerations	W*	R	same as above	
52			DocIndex	W*	R	same as above	
53			RunIndex	W*	R	same as above	
54			DocIndex RunIndex	X	X	same as above	
55		See Table 65 Partitioning Resources other than RunList for other PartIDKeys values.		W?	R?	same as above	
56	Disjointing ?		refelement	W*	R	Jog Offset	

Table 29 Disjointing

- Processes where used:
 - DigitalPrinting

Item	Attribute (@) or Element	Notes	Data Type or Value (D=Default value)	Contr	Devic	Features where used	
				oller/ Agent	e		
				Level 1	Level 1		
1	JDF/ResourcePool/DigitalPrintingParams/Disjointing/		refelement	W*	R	Jog Offset	
2	@OffsetAmount ?		integer	W?	R?	same as above	
3	@OffsetDirection ?		enumeration	W*	R	same as above	
4			Alternate	W*	R	same as above	
5			Left	W?	R?	same as above	
6			None	W*	R	same as above	
7			Right	W?	R?	same as above	

Table 30 FileSpec

- Processes where used:
 - Imposition
 - LayoutPreparation

Item	Attribute (@) or Element	Notes	Data Type or Value (D=Default value)	Contr	Devic	Features where used	
				oller/ Agent	e		
				Level 1	Level 1		
1	JDF/ResourcePool/LayoutElement/FileSpec/		refelement	W	R	Covers Document Compression Document File Format Document File Name Document Natural Language Force Page Insert Sheet Range of Pages to Include	
2	@Compression ?	Device MUST NOT process the file for any values that it does not support.	enumeration	W*	R	Document Compression	

Item	Attribute (@) or Element	Notes	Data Type or Value (D=Default value)	Contr	Devic	Features where used
				oller/ Agent Level 1	e Level 1	
3			Compress	W?	R?	same as above
4		Required for MIME multipart/related.	Base64	W*	R	same as above
5			BinHex	W?	R?	same as above
6			Deflate	W?	R?	same as above
7			Gzip	W?	R?	same as above
8			MacBinary	W?	R?	same as above
9			None (D)	W*	R	same as above
10			UUEncode	W?	R?	same as above
11			ZLIB	W?	R?	same as above
12	@DocumentNaturalLang ?		string	W?	R?	Document Natural Language
13	@MimeType ?	Device MUST NOT process the file for any values that it does not support.	string	W*	R	Document File Format
14			application/pdf	W*	R	same as above
15			application/postscript	W?	R?	same as above
16			application/octet-stream	W?	R?	same as above
17			application/vnd.hp-PCL	W?	R?	same as above
18			application/vnd.podippl+xml	W?	R?	same as above
19			ICC Profile	W?	R?	same as above
20			image/jpg	W?	R?	same as above
21			image/tiff	W?	R?	same as above
22			multipart/related	W?	R?	same as above
23			text/plain	W*	R?	same as above
24	@MimeTypeVersion ?		string	W?	R?	Document File Format
25			PS/1	W?	R?	same as above
26			PS/2	W?	R?	same as above
27			PS/3	W?	R?	same as above
28			PCL/3	W?	R?	same as above
29			PCL/4	W?	R?	same as above
30			PCL/5	W?	R?	same as above
31			PCL/5e	W?	R?	same as above
32			PCL/6	W?	R?	same as above
33			PCL/X	W?	R?	same as above
34			PDF/1.0	W?	R?	same as above
35			PDF/1.1	W?	R?	same as above
36			PDF/1.2	W?	R?	same as above
37			PDF/1.3	W?	R?	same as above
38			PDF/1.4	W?	R?	same as above
39			PDF/1.5	W?	R?	same as above
40			PDF/1.6	W?	R?	same as above
41			PDF/X-1a:2001	W?	R?	same as above
42			PDF/X-3:2002	W?	R?	same as above
43			PDF/X-1a:2003	W?	R?	same as above
44			PDF/X-3:2003	W?	R?	same as above
45			PDF/X-2:2003	W?	R?	same as above
46			PDF/PPML/VDX-2002	W?	R?	same as above
47			PDF/is-1.0	W?	R?	same as above
48			ICC-Profile/2.1.0	W?	R?	same as above
49			ICC-Profile/2.2.0	W?	R?	same as above
50			ICC-Profile/2.4.0	W?	R?	same as above
51			ICC-Profile/4.0.0	W?	R?	same as above
52			PPML/1.5	W?	R?	same as above
53			PPML/1.5	W?	R?	same as above
54			PPML/2.0	W?	R?	same as above
55			PPML/2.1	W?	R?	same as above
56			tiff/6.0	W?	R?	same as above
57	@URL ?		URL	W*	R	Covers

Item	Attribute (@) or Element	Notes	Data Type or Value (D=Default value)	Contr	Devic	Features where used
				oller/ Agent Level 1	e Level 1	
						Document File Name Force Page Insert Sheet Range of Pages to Include
58		Required for MIME multipart/related.	cid:	W*	R	same as above
59			file:	W*	R	same as above
60			http:	W*	R	same as above
61			ftp:	W?	R?	same as above
62			https:	W?	R?	same as above

Table 31 FitPolicy

- Processes where used:
 - LayoutPreparation

Item	Attribute (@) or Element	Notes	Data Type or Value (D=Default value)	Contr	Devic	Features where used
				oller/ Agent Level 1	e Level 1	
1	JDF/ResourcePool/LayoutPreparationParams/FitPolicy/		refelement	W*	R	Fit Policy
2	JDF/ResourcePool/LayoutPreparationParams/PageCell/FitPolicy/		element	W*	R	Number Up
3	@RotatePolicy ?		enumeration	W?	R?	Fit Policy
4			NoRotate	W?	R?	same as above
5			RotateOrthogonal	W?	R?	same as above
6			RotateClockwise	W?	R?	same as above
7			RotateCounterClockwise	W?	R?	same as above
8	@SizePolicy ?		enumeration	W*	R	Fit Policy Number Up
9			Abort	W?	R?	same as above
10			ClipToMaxPage	W*	R	same as above
11			FitToPage	W?	R?	same as above
12			ReduceToFit	W*	R	same as above
13			Tile	W?	R?	same as above

Table 32 FoldingParams

- Processes where used:
 - Folding

Item	Attribute (@) or Element	Notes	Data Type or Value (D=Default value)	Contr	Devic	Features where used
				oller/ Agent Level 1	e Level 1	
1	JDF/ResourcePool/FoldingParams/		element	W*	R?	Folding
2	@FoldCatalog ?		string	W*	R?	same as above

Item	Attribute (@) or Element	Notes	Data Type or Value (D=Default value)	Contr	Devic	Features where used	
				oller/ Agent	e		
				Level 1	Level 1		
3		booklets	F4-1	W*	R?	same as above	
4		brochures	F6-2	W*	R?	same as above	
5		c-fold	F6-4	W*	R?	same as above	
6		z-fold	F6-6	W*	R?	same as above	
7	@NoOp ?		boolean	W*	R	same as above	
8			false (D)	W*	R	same as above	
9			true	W*	R	same as above	
10	@PartIDKeys ?		enumerations	W*	R	same as above	
11			DocIndex	W*	R	same as above	
12			RunIndex	W*	R	same as above	
13			DocIndex RunIndex	X	X	same as above	
14		See Table 65 Partitioning Resources other than RunList for other PartIDKeys values.		W?	R?	same as above	

Table 33 HoleMakingParams

- Processes where used:
 - HoleMaking

Item	Attribute (@) or Element	Notes	Data Type or Value (D=Default value)	Contr	Devic	Features where used	
				oller/ Agent	e		
				Level 1	Level 1		
1	JDF/ResourcePool/HoleMakingParams/		element	W*	R?	Punching and Hole Making	
2	@HoleType ?		enumeration	W*	R?	same as above	
3			S-generic	W*	R?	same as above	
4			S1-generic	W*	R?	same as above	
5			R2-generic	W*	R?	same as above	
6			R3-generic	W*	R?	same as above	
7			R4-generic	W*	R?	same as above	
8			R5-generic	W*	R?	same as above	
9	@NoOp ?		boolean	W*	R	same as above	
10			false (D)	W*	R	same as above	
11			true	W*	R	same as above	
12	@PartIDKeys ?		enumerations	W*	R	same as above	
13			DocIndex	W*	R	same as above	
14			RunIndex	W*	R	same as above	
15			DocIndex RunIndex	X	X	same as above	
16		See Table 65 Partitioning Resources other than RunList for other PartIDKeys values.		W?	R?	same as above	

Table 34 ImageShift

- Processes where used:
 - LayoutPreparation

Item	Attribute (@) or Element	Notes	Data Type or Value (D=Default value)	Contr	Devic	Features where used	
				oller/ Agent	e		
				Level 1	Level 1		
1	JDF/		element	W*	R	Fit Policy	

Item	Attribute (@) or Element	Notes	Data Type or Value (D=Default value)	Contr	Devic	Features where used
				oller/ Agent	e	
				Level 1	Level 1	
	ResourcePool/ LayoutPreparationParams/ ImageShift/					Image Shift Back Side Image Shift Front Side
2	@PositionX ?		enumeration	W?	R?	Fit Policy
3			Center	W?	R?	same as above
4			Left	W?	R?	same as above
5			Right	W?	R?	same as above
6			None	W?	R?	same as above
7	@PositionY ?		enumeration	W?	R?	same as above
8			Center	W?	R?	same as above
9			Left	W?	R?	same as above
10			Right	W?	R?	same as above
11			None	W?	R?	same as above
12	@ShiftBack ?		XYPair (doubles)	W*	R	Image Shift Back Side
13	@ShiftFront ?		XYPair (doubles)	W*	R	Image Shift Front Side

Table 35 InsertSheet

- Processes where used:
 - Imposition
 - LayoutPreparation

Item	Attribute (@) or Element	Notes	Data Type or Value (D=Default value)	Contr	Devic	Features where used
				oller/ Agent	e	
				Level 1	Level 1	
1	JDF/ ResourcePool/ RunList/ InsertSheet/		refelement	W*	R	Covers Force Page Insert Sheet
2	JDF/ ResourcePool/ LayoutPreparationParams/ InsertSheet/		refelement	W*	R	Interleave Sheets Start, Separator/Slip, End Sheets
3	@IncludeInBundleItem		enumeration	W?	R?	Start, Separator/Slip, End Sheets
4			After	W?	R?	same as above
5			Before	W?	R?	same as above
6			New	W?	R?	same as above
7			None	W?	R?	same as above
8	@IsWaste ?		boolean	W?	R?	Covers Force Page Insert Sheet Interleave Sheets Start, Separator/Slip, End Sheets
9			false	W?	R?	Covers Force Page Insert Sheet Interleave Sheets Start, Separator/Slip, End Sheets
10			true	W?	R?	Start, Separator/Slip, End Sheets
11	@SheetFormat ?		NMTOKEN	W*	R	Covers Force Page Interleave Sheets Start, Separator/Slip, End Sheets

Item	Attribute (@) or Element	Notes	Data Type or Value (D=Default value)	Contr	Devic	Features where used
				oller/ Agent Level 1	e Level 1	
12			Blank	W*	R	Covers Force Page Interleave Sheets Start, Separator/Slip, End Sheets
13			Brief	W?	R?	Start, Separator/Slip, End Sheets
14			Duplicate	W?	R?	Interleave Sheets
15			Full	W?	R?	Start, Separator/Slip, End Sheets
16			Standard	W*	R	Start, Separator/Slip, End Sheets
17	@SheetType		enumeration	W	R	Covers Force Page Interleave Sheets Start, Separator/Slip, End Sheets
18			FillSheet	W*	R	Covers Force Page
19			InsertSheet	W*	R	Insert Sheet
20			JobSheet	W*	R	Start, Separator/Slip, End Sheets
21			SeparatorSheet	W*	R	Interleave Sheets Start, Separator/Slip, End Sheets
22	@SheetUsage		enumeration	W	R	Covers Force Page Insert Sheet Interleave Sheets Start, Separator/Slip, End Sheets
23			FillForceBack	W	R	Covers Force Page
24			FillForceFront	W	R	Covers Force Page
25			Interleaved	W?	R?	Interleave Sheets
26			InterleavedBefore	W?	R?	Interleave Sheets
27			Header	W	R	Insert Sheet Start, Separator/Slip, End Sheets
28			Trailer	W	R	Insert Sheet Start, Separator/Slip, End Sheets
29			Slip	W	R	Start, Separator/Slip, End Sheets
30			SlipCopy	W	R	Start, Separator/Slip, End Sheets
31	RunList ?		refelement	W?	R?	Insert Sheet
32	Sheet ?		refelement	W*	R	Insert Sheet Interleave Sheets Start, Separator/Slip, End Sheets

Table 36 InterpretingParams

- Processes where used:
 - Interpreting

Item	Attribute (@) or Element	Notes	Data Type or Value (D=Default value)	Contr	Devic	Features where used
				oller/ Agent	e	

				Level 1	Level 1	
1	JDF/ResourcePool/InterpretingParams/		element	W	R	Print Quality
2	@PrintQuality ?		enumeration	W*	R	same as above
3			Draft	W*	R?	same as above
4			High	W*	R?	same as above
5			Normal	W*	R	same as above
6	@PartIDKeys ?		enumerations	W*	R	same as above
7			DocIndex	W*	R	same as above
8			RunIndex	W*	R	same as above
9			DocIndex RunIndex	X	X	same as above
10		See Table 65 Partitioning Resources other than RunList for other PartIDKeys values.		W?	R?	same as above

Table 37 JobField

- Processes where used:
 - LayoutPreparation

Item	Attribute (@) or Element	Notes	Data Type or Value (D=Default value)	Controller/Agent	Device	Features where used
				Level 1	Level 1	
1	JDF/ResourcePool/LayoutPreparationParams/InsertSheet/Sheet/Surface/MarkObject/JobField/		refelement	W?	R?	Start, Separator/Slip, End Sheets
2	@ShowList		NMTOKENS	W?	R?	same as above
3			UserText	W?	R?	same as above
4			JobName	W?	R?	same as above
5			JobSubmitterName	W?	R?	same as above
6	@UserText ?		string	W?	R?	same as above

Table 38 LayoutElement

- Processes where used:
 - Imposition
 - LayoutPreparation

Item	Attribute (@) or Element	Notes	Data Type or Value (D=Default value)	Controller/Agent	Device	Features where used
				Level 1	Level 1	
1	JDF/ResourcePool/LayoutElement/		element	W*	R	Covers Document Compression Document File Format Document File Name Document Natural Language Force Page Insert Sheet Range of Pages to Include
2	FileSpec ?		refelement	W*	R	Covers Document Compression Document File Format

Item	Attribute (@) or Element	Notes	Data Type or Value (D=Default value)	Contr	Devic	Features where used
				oller/ Agent	e	
				Level 1	Level 1	
						Document File Name Document Natural Language Force Page Insert Sheet Range of Pages to Include

Table 39 LayoutPreparationParams

- Processes where used:
 - LayoutPreparation

Item	Attribute (@) or Element	Notes	Data Type or Value (D=Default value)	Contr	Devic	Features where used
				oller/ Agent	e	
				Level 1	Level 1	
1	JDF/ ResourcePool/ LayoutPreparationParams/		element	W	R	Covers Fit Policy Image Shift Back Side Image Shift Front Side Input Tray Name Interleave Sheets Media Number Up Start, Separator/Slip, End Sheets
2	@NumberUp ?		2 integers	W*	R	Number Up
3	@PageDistributionScheme ?		enumeration	W*	R	Page Distribution
4			Perfect	W*	R	same as above
5			Saddle	W*	R	same as above
6			Sequential (D)	W*	R	same as above
7	@PageOrder		enumeration	W*	R	Page Order
8			Booklet	W*	R	same as above
9			Reader (D)	W*	R	same as above
10	@PresentationDirection ?		enumeration	W*	R	Presentation Direction Number Up
11			FoldCatalog	W*	R	same as above
12			Yxz	W*	R	same as above
13	@Rotate ?		enumeration	W*	R	Rotate Sheet Content
14			Rotate0 (D)	W*	R	same as above
15			Rotate90	W*	R	same as above
16			Rotate180	W*	R	same as above
17			Rotate270	W*	R	same as above
18	@Sides ?		enumeration	W*	R	Covers Sides
19			OneSidedBackFlipX	W*	R	same as above
20			OneSidedBackFlipY	W*	R	same as above
21			OneSidedFront (D)	W*	R	same as above
22			TwoSidedBackFlipX	W*	R	same as above
23			TwoSidedBackFlipY	W*	R	same as above
24	@PartIDKeys ?		enumerations	W*	R	same as above
25			DocIndex	W*	R	same as above
26			RunIndex	W*	R	same as above
27			DocIndex RunIndex	X	X	same as above
28		See Table 65 Partitioning Resources other than RunList for other PartIDKeys values.		W?	R?	same as above
29	FitPolicy ?		refelement	W*	R	Fit Policy
30	ImageShift ?		element	W*	R	Fit Policy

Item	Attribute (@) or Element	Notes	Data Type or Value (D=Default value)	Contr	Devic	Features where used
				oller/ Agent Level 1	e Level 1	
						Image Shift Back Side Image Shift Front Side
31	InsertSheet ?		refelement	W*	R	Interleave Sheets Start, Separator/Slip, End Sheets
32	PageCell?		element	W*	R	Number Up

Table 40 Location

- Processes where used:
 - N/A

Item	Attribute (@) or Element	Notes	Data Type or Value (D=Default value)	Contr	Contr	Features where used
				oller/ Agent Level 1	oller/ Agent Level 1	
1	JDF/ ResourcePool/ Media/ Location/		refelement	W*	R	Input Tray Name
2	@LocationName ?		string	W*	R	same as above
3			AnySmallFormat	W?	R?	same as above
4			AnyLargeFormat	W?	R?	same as above
5			AutoSelect	W?	R?	same as above
6		Same as Lower	Bottom	W?	R?	same as above
7			BypassTray	W?	R?	same as above
8			BypassTray-n	W?	R?	same as above
9			Continuous	W?	R?	same as above
10			Disc	W?	R?	same as above
11			Disc-n	W?	R?	same as above
12			Envelope	W?	R?	same as above
13			Envelope-n	W?	R?	same as above
14			Front	W?	R?	same as above
15			InsertTray	W?	R?	same as above
16			InsertTray-n	W?	R?	same as above
17		Same as Main	LargeCapacity	W*	R	same as above
18			LargeCapacity-n	W?	R?	same as above
19			Left	W?	R?	same as above
20		Same as Center	Middle	W?	R?	same as above
21			Rear	W?	R?	same as above
22			Right	W?	R?	same as above
23			Roll	W?	R?	same as above
24			Roll-n	W?	R?	same as above
25			Side	W?	R?	same as above
26		Same as Upper	Top	W*	R	same as above
27			Tray	W?	R?	same as above
28		Same as Cassette	Tray-n	W?	R?	same as above

Table 41 MarkObject

- Processes where used:
 - LayoutPreparation

Item	Attribute (@) or Element	Notes	Data Type or Value (D=Default value)	Contr	Devic	Features where used
				oller/ Agent	e	

				Level 1	Level 1	
1	JDF/ ResourcePool/ LayoutPreparationParams/ InsertSheet/ Sheet/ Surface/ MarkObject/		element	W?	R?	Start, Separator/Slip, End Sheets
2	JobField *		refelement	W?	R?	same as above

Table 42 Media

- Processes where used:
 - DigitalPrinting
 - LayoutPreparation
 - Imposition

Item	Attribute (@) or Element	Notes	Data Type or Value (D=Default value)	Controller/Agent	Device	Features where used
				Level 1	Level 1	
1	JDF/ ResourcePool/ Media/		element	W*	R	Covers Media Insert Sheet Interleave Sheets Start, Separator/Slip, End Sheets
2	JDF/ ResourcePool/ RunList/ InsertSheet/ Sheet/ Media/		refelement	W*	R	Covers Insert Sheet
3	JDF/ ResourcePool/ LayoutPreparationParams/ InsertSheet/ Sheet/ Media/		refelement	W*	R	Interleave Sheets Start, Separator/Slip, End Sheets
4	JDF/ ResourcePool/ DigitalPrintingParams/ Media/		refelement	W*	R	Covers Media
5	@Amount		double	W?	R?	same as above
6	@BackCoatings ?		enumeration	W*	R?	same as above
7			Coated	W*	R?	same as above
8			Glossy	W*	R?	same as above
9			HighGloss	W*	R?	same as above
10			InkJet	W*	R?	same as above
11			Matte	W*	R?	same as above
12			Satin	W*	R?	same as above
13			Semigloss	W*	R?	same as above
14			None	W*	R?	same as above
15	@Brand ?		string	W*	R?	same as above
16	@DescriptiveName ?		string	W*	R	same as above
17	@Dimension ?		XYPair (doubles)	W*	R?	same as above
18	@FrontCoatings ?	See @BackCoatings for valid values	enumeration	W*	R?	same as above
19	@HoleType ?		enumeration	W*	R?	same as above
20			None (D)	W*	R?	same as above
21			S-generic	W*	R?	same as above
22			S1-generic	W*	R?	same as above
23			R2-generic	W*	R?	same as above
24			R3-generic	W*	R?	same as above

Item	Attribute (@) or Element	Notes	Data Type or Value (D=Default value)	Contr	Devic	Features where used
				oller/ Agent Level 1	e Level 1	
25			R4-generic	W*	R?	same as above
26			R5-generic	W*	R?	same as above
27	@ImageableSide ?		enumeration	W*	R?	same as above
28			Back	W*	R?	same as above
29			Both	W*	R?	same as above
30			Front	W*	R?	same as above
31			Neither	W*	R?	same as above
32	@LabColorValue ?		LabColor	W?	R?	same as above
33	@MediaColorName ?		NamedColor	W*	R?	same as above
34		All values of MediaColorName.		W?	R?	same as above
35	@MediaColorNameDetails ?		string	W*	R?	same as above
36	@MediaSetCount ?		integer	W*	R?	same as above
37	@MediaType ?		enumeration	W*	R?	same as above
38			Disc	W?	R?	same as above
39			Other	W?	R?	same as above
40			Paper	W*	R?	same as above
41			Transparency	W*	R?	same as above
42	@MediaTypeDetails ?		NMTOKEN	W*	R?	same as above
43			CardBoard	W*	R?	same as above
44			ContinuousLong	W*	R?	same as above
45			ContinuousShort	W*	R?	same as above
46			Envelope	W*	R?	same as above
47			EnvelopePlain	W*	R?	same as above
48			EnvelopeWindow	W*	R?	same as above
49			FullCutTabs	W*	R?	same as above
50			Labels	W*	R?	same as above
51			Letterhead	W*	R?	same as above
52			MultiLayer	W*	R?	same as above
53			MultiPartForm	W*	R?	same as above
54			Photographic	W*	R?	same as above
55			PreCutTabs	W*	R?	same as above
56		Same as Paper	Stationery	W*	R?	same as above
57			TabStock	W*	R?	same as above
58			Tractor	W*	R?	same as above
59	@MediaUnit ?		enumeration	W*	R?	same as above
60			Continuous	W*	R?	same as above
61			Roll	W*	R?	same as above
62			Sheet (D)	W*	R?	same as above
63	@Opacity ?		enumeration	W*	R?	same as above
64			Opaque	W*	R?	same as above
65			Transparent	W*	R?	same as above
66			Translucent	W*	R?	same as above
67	@PartIDKeys ?		enumeration	W*	R	same as above
68			Location	W*	R	same as above
69	@PrePrinted ?		boolean	W*	R?	same as above
70			false (D)	W*	R?	same as above
71			true	W*	R?	same as above
72	@ProductID ?		string	W*	R?	MIS Support
73	@StockType ?	Required if Weight is specified.	NMTOKEN	W*	R?	Media
74			Bristol	W*	R?	same as above
75			Bond	W*	R?	same as above
76			Cover	W*	R?	same as above
77			Index	W*	R?	same as above
78			Newsprint	W*	R?	same as above
79		This includes book stock	Offset	W*	R?	same as above
80			Tag	W*	R?	same as above
81			Text	W*	R?	same as above
82	@Weight ?	MUST also specify StockType.	double	W*	R?	same as above
83	Comment ?		element	W*	R	same as above
84	Location ?		refelement	W*	R	same as above

Table 43 MediaLink

- Processes where used:
 - DigitalPrinting

Item	Attribute (@) or Element	Notes	Data Type or Value (D=Default value)	Contr	Devic	Features where used
				oller/ Agent	e	
				Level 1	Level 1	
1	JDF/ ResourceLinkPool/ @Orientation ?		element	W	R	Feed Orientation
2			enumeration	W?	R?	same as above
3			Rotate0	W?	R?	same as above
4			Rotate90	W?	R?	same as above
5			Rotate180	W?	R?	same as above
6			Rotate270	W?	R?	same as above
7			Flip0	W?	R?	same as above
8			Flip90	W?	R?	same as above
9			Flip180	W?	R?	same as above
10			Flip270	W?	R?	same as above

Table 44 MediaRef

- Processes where used:
 - DigitalPrinting
 - LayoutPreparation
 - Imposition

Item	Attribute (@) or Element	Notes	Data Type or Value (D=Default value)	Contr	Devic	Features where used
				oller/ Agent	e	
				Level 1	Level 1	
1	JDF/ ResourcePool/ RunList/ InsertSheet/ Sheet/ MediaRef/		refelement	W*	R	Covers Insert Sheet
2	JDF/ ResourcePool/ LayoutPreparationParams/ InsertSheet/ Sheet/ MediaRef/		refelement	W*	R	Interleave Sheets Start, Separator/Slip, End Sheets
3	JDF/ ResourcePool/ DigitalPrintingParams/ MediaRef/		refelement	W*	R	Covers Media
4	Part *		element	W*	R	Covers Media Insert Sheet Interleave Sheets Start, Separator/Slip, End Sheets

Table 45 NodeInfo

- Processes where used:
 - N/A

Item	Attribute (@) or Element	Notes	Data Type or Value (D=Default value)	Controller/Agent	Device	
				Level 1	Level 1	
1	JDF/NodeInfo/		element	W*	R	Job Priority
2	@JobPriority ?		integer	W*	R	Job Priority
3	@Route ?		URL	W*	R	Destination or Physical Printer Requested

Table 46 ObjectResolution

- Processes where used:
 - Rendering

Item	Attribute (@) or Element	Notes	Data Type or Value (D=Default value)	Controller/Agent	Device	Features where used
				Level 1	Level 1	
1	JDF/RenderingParams/ObjectResolution/		refelement	W?	R?	Approval Destination or Physical Printer Resolution
2	@Resolution		XYPair	W	R	same as above

Table 47 Part

- Processes where used:
 - Imposition
 - LayoutPreparation

Item	Attribute (@) or Element	Notes	Data Type or Value (D=Default value)	Controller/Agent	Device	Features where used
				Level 1	Level 1	
1	JDF/ResourceLinkPool/RunListLink/Part/		element	W*	R	Range of Pages to Output
2	JDF/ResourcePool/MediaRef/Part/		element	W*	R	Covers Media Insert Sheet Interleave Sheets Start, Separator/Slip, End Sheets
3	@DocIndex		IntegerList	W*	R	Range of Pages to Output
4	@RunIndex		IntegerList	W*	R	Range of Pages to Output
5	@Location		string	W*	R	Covers Media Insert Sheet Interleave Sheets Start, Separator/Slip, End Sheets

Table 48 Person

- Processes where used:

- o N/A

Item	Attribute (@) or Element	Notes	Data Type or Value (D=Default value)	Contr	Devic	Features where used
				oller/ Agent	e	
				Level 1	Level 1	
1	JDF/ CustomerInfo/ Contact/ Person/		refelement	W?	R?	Approval Contact Information Proof Print
2	@FamilyName ?		string	W?	R?	same as above
3	@FirstName ?		string	W?	R?	same as above

Table 49 PageCell

- Processes where used:
 - o LayoutPreparation

Item	Attribute (@) or Element	Notes	Data Type or Value (D=Default value)	Contr	Devic	Features where used
				oller/ Agent	e	
				Level 1	Level 1	
1	JDF/ LayoutPreparationParams PageCell/		refelement	W*	R	Number Up
2	@Rotate ?		string	W*	R	same as above
3			Rotate0 (D)	W*	R	same as above
4			Rotate90	W*	R	same as above
5			Rotate180	W*	R	same as above
6			Rotate270	W*	R	same as above
7	FitPolicy ?		refelement	W*	R	same as above

Table 50 RenderingParams

- Processes where used:
 - o Rendering

Item	Attribute (@) or Element	Notes	Data Type or Value (D=Default value)	Contr	Devic	Features where used
				oller/ Agent	e	
				Level 1	Level 1	
1	JDF/ ResourcePool/ RenderingParams/		element	W	R	Approval Black Overprint Destination or Physical Printer Resolution
2	AutomatedOverPrintParams ?		refelement	W?	R?	Black Overprint
3	ObjectResolution *		refelement	W?	R?	Approval Destination or Physical Printer Resolution
4	@PartIDKeys ?		enumerations	W*	R	same as above
5			DocIndex	W*	R	same as above
6			RunIndex	W*	R	same as above
7			DocIndex RunIndex	X	X	same as above
8		See Table 65 Partitioning Resources other than RunList for other PartIDKeys values.		W?	R?	same as above

Table 51 ResourceLinkPool

- Processes where used:
 - N/A

Item	Attribute (@) or Element	Notes	Data Type or Value (D=Default value)	Controller/Agent	Device	Features where used
				Level 1	Level 1	
1	JDF/ResourceLinkPool/		element	W	R	All
2	ApprovalParamsLink ?	See Table 8 All ResourceLink elements for attributes	element	W*	R	Proof Print
3	ColorantControlLink ?	See Table 8 All ResourceLink elements for attributes	element	W*	R	Spot Color
4	ComponentLink	Also see Table 8 All ResourceLink elements for additional attributes	element	W	R	Number of Copies Binding Folding Punching and Hole Making Stapling and Stitching
5	CoverApplicationParamsLink ?	See Table 8 All ResourceLink elements for attributes	element	W*	R?	Binding
6	DeviceLink ?	See Table 8 All ResourceLink elements for attributes	element	W*	R	Destination or Physical Printer Requested
7	DigitalPrintingParamsLink	See Table 8 All ResourceLink elements for attributes	element	W	R	Collate Input Tray Name Jog Offset Margins Output Bin Name Page Delivery Proof Print
8	FoldingParamsLink ?	See Table 8 All ResourceLink elements for attributes	element	W*	R?	Folding
9	HoleMakingParamsLink ?	See Table 8 All ResourceLink elements for attributes	element	W*	R?	Punching and Hole Making
10	InterpretingParamsLink	See Table 8 All ResourceLink elements for attributes	element	W	R	Print Quality
11	LayoutPreparationParamsLink	See Table 8 All ResourceLink elements for attributes	element	W	R	Covers Fit Policy Image Shift Back Side Image Shift Front Side Input Tray Name Interleave Sheets Media Number Up Start, Separator/Slip, End Sheets
12	MediaLink ?	Also see Table 8 All ResourceLink elements for additional attributes	element	W*	R	Covers Media Insert Sheet Interleave Sheets Start, Separator/Slip, End Sheets
13	RenderingParamsLink	See Table 8 All ResourceLink elements for attributes	element	W	R	Approval Black Overprint Destination or Physical Printer Resolution Proof Print
14	RunListLink	Also see	element	W	R	Covers

Item	Attribute (@) or Element	Notes	Data Type or Value (D=Default value)	Contr	Devic	Features where used
				oller/ Agent	e	
				Level 1	Level 1	
		Table 8 All ResourceLink elements for additional attributes				Document Compression Document File Format Document File Name Document Natural Language Force Page Insert Sheet Range of Pages to Include
15	ScreeningParamsLink ?	See Table 8 All ResourceLink elements for attributes	element	W*	R	Screening
16	SpineTapingParamsLink ?	See Table 8 All ResourceLink elements for attributes	element	W*	R?	Binding
17	StitchingParamsLink ?	See Table 8 All ResourceLink elements for attributes	element	W*	R?	Stapling and Stitching
18	TrappingDetailsLink ?	See Table 8 All ResourceLink elements for attributes	element	W*	R	Trapping
19	TrimmingParamsLink ?	See Table 8 All ResourceLink elements for attributes	element	W*	R?	Trimming

Table 52 ResourcePool

- Processes where used:
 - N/A

Item	Attribute (@) or Element	Notes	Data Type or Value (D=Default value)	Contr	Devic	Features where used
				oller/ Agent	e	
				Level 1	Level 1	
1	JDF/ResourcePool/		element	W	R	All
2	ApprovalParams?		element	W*	R	Proof Print
3	ColorantControl?		element	W*	R	Spot Color
4	Component		element	W	R	Number of Copies Binding Folding Punching and Hole Making Stapling and Stitching
5	CoverApplicationParams ?		element	W*	R?	Binding
6	Device?		element	W*	R	Destination or Physical Printer Requested
7	DigitalPrintingParams		element	W	R	Collate Input Tray Name Jog Offset Margins Output Bin Name Page Delivery Proof Print
8	FoldingParams?		element	W*	R?	Folding
9	HoleMakingParams?		element	W*	R?	Punching and Hole Making
10	InterpretingParams		element	W	R	Print Quality
11	LayoutElement ?		element	W	R	Covers Document Compression Document File Format Document File Name Document Natural Language

Item	Attribute (@) or Element	Notes	Data Type or Value (D=Default value)	Contr	Devic	Features where used
				oller/ Agent Level 1	e Level 1	
						Force Page Insert Sheet Range of Pages to Include
12	LayoutPreparationParams		element	W	R	Covers Fit Policy Image Shift Back Side Image Shift Front Side Input Tray Name Interleave Sheets Media Number Up Start, Separator/Slip, End Sheets
13	Media?		element	W*	R	Covers Media Insert Sheet Interleave Sheets Start, Separator/Slip, End Sheets
14	RenderingParams		element	W	R	Approval Black Overprint Destination or Physical Printer Resolution Proof Print
15	RunList		element	W	R	Covers Document Compression Document File Format Document File Name Document Natural Language Force Page Insert Sheet Range of Pages to Include
16	ScreeningParams?		element	W*	R	Screening
17	SpineTapingParams ?		element	W*	R?	Binding
18	StitchingParams?		element	W*	R?	Stapling and Stitching
19	TrappingDetails?		element	W*	R	Trapping
20	TrimmingParams?		element	W*	R?	Trimming

Table 53 RunList

- Processes where used:
 - Imposition
 - LayoutPreparation

Item	Attribute (@) or Element	Notes	Data Type or Value (D=Default value)	Contr	Devic	Features where used
				oller/ Agent Level 1	e Level 1	
1	JDF/ ResourcePool/ RunList/		element	W	R	Covers Document Compression Document File Format Document File Name Document Natural Language Force Page Insert Sheet Range of Pages to Include
2	@ComponentGranularity ?		enumeration	W*	R	same as above
3			All	W*	R	same as above
4			Document (D)	W*	R	same as above
5			BundleItem	W?	R?	same as above

Item	Attribute (@) or Element	Notes	Data Type or Value (D=Default value)	Contr	Devic	Features where used
				oller/ Agent Level 1	e Level 1	
6			Page	W?	R?	same as above
7			Set	W?	R?	same as above
8	@Directory ?		URL	W?	R	same as above
9	@EndOfBundleItem ?		boolean	W?	R?	same as above
10			false	W?	R?	same as above
11			true	W?	R?	same as above
12	@EndOfDocument ?		boolean	W*	R	same as above
13			false	W*	R	same as above
14			true	W*	R	same as above
15	@EndOfSet ?		boolean	W?	R?	same as above
16			false	W?	R?	same as above
17			true	W?	R?	same as above
18	@NPage ?		integer	W?	R?	same as above
19	@Pages ?		IntegerRangeList	W*	R	Covers Force Page Insert Sheet Range of Pages to Include
20	@PageCopies ?	If present, MUST only appear as an attribute of the RunList that is a subelement of an InsertSheet.	integer	W?	R?	Insert Sheet
21	@PartIDKeys ?		enumerations	W*	R	Covers Document Compression Document File Format Document File Name Document Natural Language Force Page Insert Sheet Range of Pages to Include
22			Run	W*	R	same as above
23	InsertSheet ?		refelement	W*	R	Covers Force Page Insert Sheet
34	LayoutElement ?		refelement	W*	R	Covers Document Compression Document File Format Document File Name Document Natural Language Force Page Insert Sheet Range of Pages to Include

Table 54 RunListLink

- Processes where used:
 - Imposition
 - LayoutPreparation

Item	Attribute (@) or Element	Notes	Data Type or Value (D=Default value)	Contr	Devic	Features where used
				oller/ Agent Level 1	e Level 1	
1	JDF/ ResourceLinkPool/ RunListLink/		element	W	R	Range of Pages to Output
2	Part *		element	W*	R	Range of Pages to Output

Table 55 ScreeningParams

- Processes where used:
 - Screening

Item	Attribute (@) or Element	Notes	Data Type or Value (D=Default value)	Contr	Devic	Features where used
				oller/ Agent	e	
				Level 1	Level 1	
1	JDF/ResourcePool/ScreeningParams/		element	W*	R	Screening
2	@PartIDKeys ?		enumerations	W*	R	same as above
3			DocIndex	W*	R	same as above
4			RunIndex	W*	R	same as above
5			DocIndex RunIndex	X	X	same as above
6		See Table 65 Partitioning Resources other than RunList for other PartIDKeys values.		W?	R?	same as above
7	ScreenSelector *		element	W*	R	same as above

Table 56 ScreenSelector

- Processes where used:
 - Screen

Item	Attribute (@) or Element	Notes	Data Type or Value (D=Default value)	Contr	Devic	Features where used
				oller/ Agent	e	
				Level 1	Level 1	
1	JDF/ResourcePool/ScreeningParams/ScreenSelector/		element	W*	R	Screening
2	@ScreeningFamily ?		string	W*	R?	same as above
3	@ScreeningType ?		enumeration	W*	R	same as above
4			Adaptive	W?	R?	same as above
5			AM	W?	R?	same as above
6			ErrorDiffusion	W?	R?	same as above
7			FM	W?	R?	same as above
8			HybridAM-FM	W?	R?	same as above
9			HybridAMline-dot	W?	R?	same as above

Table 57 SeparationSpec

- Processes where used:
 - Interpreting

Item	Attribute (@) or Element	Notes	Data Type or Value (D=Default value)	Contr	Devic	Features where used
				oller/ Agent	e	
				Level 1	Level 1	
1	JDF/ResourcePool/ColorantControl/ColorantParams/SeparationSpec/		refelement	W*	R	Spot Color
2	@Name		string	W*	R	same as above

Table 58 Sheet

- Processes where used:
 - Imposition
 - LayoutPreparation

Item	Attribute (@) or Element	Notes	Data Type or Value (D=Default value)	Contr	Devic	Features where used
				oller/ Agent	e	
				Level 1	Level 1	
1	JDF/ResourcePool/RunList/InsertSheet/Sheet/		refelement	W*	R	Insert Sheet
2	JDF/ResourcePool/LayoutPreparationParams/InsertSheet/Sheet/		refelement	W*	R	Interleave Sheets Start, Separator/Slip, End Sheets
3	Media ?		refelement	W*	R	Insert Sheet Interleave Sheets Start, Separator/Slip, End Sheets
4	Surface?		refelement	W?	R?	Start, Separator/Slip, End Sheets

Table 59 SpineTapingParams

- Processes where used:
 - SpineTaping

Item	Attribute (@) or Element	Notes	Data Type or Value (D=Default value)	Contr	Devic	Features where used
				oller/ Agent	e	
				Level 1	Level 1	
1	JDF/ResourcePool/SpineTapingParams/		element	W*	R?	Binding
2	@NoOp ?		boolean	W?	R	same as above
3			false (D)	W?	R	same as above
4			true	W?	R	same as above
5	@PartIDKeys ?		enumerations	W*	R	same as above
6			DocIndex	W*	R	same as above
7			RunIndex	W*	R	same as above
8			DocIndex RunIndex	X	X	same as above
9		See Table 65 Partitioning Resources other than RunList for other PartIDKeys values.		W?	R?	same as above

Table 60 StitchingParams

- Processes where used:
 - Stitching

Item	Attribute (@) or Element	Notes	Data Type or Value (D=Default value)	Contr	Devic	Features where used
				oller/ Agent	e	

				Level 1	Level 1	
1	JDF/ResourcePool/StitchingParams/		element	W*	R?	Stapling and Stitching
2	@Angle ?		double	W?	R?	same as above
3	@NoOp ?		boolean	W?	R	same as above
4			false (D)	W?	R	same as above
5			true	W?	R	same as above
6	@NumberOfStitches?		integer	W?	R?	same as above
7	@PartIDKeys ?		enumerations	W*	R	same as above
8			DocIndex	W*	R	same as above
9			RunIndex	W*	R	same as above
10			DocIndex RunIndex	X	X	same as above
11		See Table 65 Partitioning Resources other than RunList for other PartIDKeys values.		W?	R?	same as above
12	@StitchType ?		enumeration	W*	R	same as above
13			Corner	W*	R	same as above
14			Saddle	W*	R?	same as above
15			Side	W*	R?	same as above

Table 61 Surface

- Processes where used:
 - LayoutPreparation

Item	Attribute (@) or Element	Notes	Data Type or Value (D=Default value)	Controller/Agent	Device	Features where used
				Level 1	Level 1	
1	JDF/ResourcePool/LayoutPreparationParams/InsertSheet/Sheet/Surface/		relement	W?	R?	Start, Separator/Slip, End Sheets
2	@Side		enumeration	W	R	same as above
3			Back	W?	R?	same as above
4			Front	W*	R	same as above
3	MarkObject *		element	W?	R?	same as above

Table 62 TrappingDetails

- Processes where used:
 - Trapping

Item	Attribute (@) or Element	Notes	Data Type or Value (D=Default value)	Controller/Agent	Device	Features where used
				Level 1	Level 1	
1	JDF/ResourcePool/TrappingDetails/		element	W*	R?	Trapping
2	@NoOp ?		boolean	W*	R	same as above
3			false (D)	W*	R	same as above
4			true	W*	R	same as above
5	@PartIDKeys ?		enumerations	W*	R	same as above
6			DocIndex	W*	R	same as above
7			RunIndex	W*	R	same as above
8			DocIndex RunIndex	X	X	same as above

Item	Attribute (@) or Element	Notes	Data Type or Value (D=Default value)	Contr	Devic	Features where used
				oller/ Agent Level 1	e Level 1	
9		See Table 65 Partitioning Resources other than RunList for other PartIDKeys values.		W?	R?	same as above

Table 63 TrimmingParams

- Processes where used:
 - Trimming

Item	Attribute (@) or Element	Notes	Data Type or Value (D=Default value)	Contr	Devic	Features where used
				oller/ Agent Level 1	e Level 1	
1	JDF/ ResourcePool/ TrimmingParams/		element	W*	R?	Trimming
2	@NoOp ?		boolean	W*	R	same as above
3			false (D)	W*	R	same as above
4			true	W*	R	same as above
5	@PartIDKeys ?		enumerations	W*	R	same as above
6			DocIndex	W*	R	same as above
7			RunIndex	W*	R	same as above
8			DocIndex RunIndex	X	X	same as above
9		See Table 65 Partitioning Resources other than RunList for other PartIDKeys values.		W?	R?	same as above

3.1.8.1 Resource References

In some cases, it is possible that more than one Resource references (uses or contains) another Resource. Instead of defining the referenced Resource twice and risking that when updating one definition, the other definition is forgotten and not updated, a Resource reference (Inter-Resource Linking) can be used. Using a Resource reference is also a way to isolate a Resource definition from the Resources that use or contain it.

The Integrated Digital Printing ICS allows for the use of resource References instead of imbedding resources inside of other Resources.

In the following example a Media Resource is declared in the ResourcePool. The DigitalPrintingParams and Sheet Resources each use a resource reference to refer to the Media Resource. Note the addition of the “Ref” suffix when the DigitalPrintingParams and Sheet Resources reference the Media Resource and the use of the rRef attribute to identify the Media Resource by its ID attribute. It is clear that the same Media resource is being referenced by both the DigitalPrintingParams and Sheet resources, and any updates to the Media Resource will only have to be made in one place.

```

.....
<ResourcePool>
...
  <Media ID="TopTray" Class="Consumable" Status="Available" >
    <Location LocationName="top"/>
  </Media><LayoutPreparationParams ID="LPP" Class="Parameter" Status="Available" >
    <InsertSheet ... >
      <Sheet>
        <MediaRef rRef="TopTray" />
      </Sheet>
    </InsertSheet>
  </LayoutPreparationParams>
  <DigitalPrintingParams ID="DPP" Class="Parameter" Status="Available" >
    <MediaRef rRef="TopTray" />
  </DigitalPrintingParams>
...
</ResourcePool>
...

```

3.1.8.2 Partitioning Resources

Part of a Resource may have to be defined or referenced separately from another part of the Resource. For example, specific pages of a job are to be printed on the front side of the sheet and the rest of the job is to be printed on both sides of the sheet. A partitioned Resource contains nested child Resource elements, each with the same name as the Resource.

Following are tables that list the valid combination of the partition keys that this application note supports and a description of when each is used.

Table 64 Partitioning RunList

#	Description	Partition Keys	Comments
1	Select specific files or portions of a file or files.	Run	<p>EndOfDocument or EndOfSet may be implied from the PDL if the PDL supports internal documents and/or sets.</p> <p>If the PDL does not support internal documents or sets then specify EndOfDocument, EndOfSet for each RunList partition so that DocIndex or SetIndex can be used to partition other resources to select specific documents or sets.</p> <p>Specify EndOfBundleItem for each RunList partition so that</p>

			BundleItemIndex can be used to partition other resources to select specific bundles.
--	--	--	--

Table 65 Partitioning Resources other than RunList

- The following resources can be partitioned using the partition keys in the following table:
 - ColorantControl
 - CoverApplicationParams
 - DigitalPrintingParams
 - FoldingParams
 - HoleMakingParams
 - InterpretingParams
 - LayoutPreparationParams
 - RenderingParams
 - ScreeningParams
 - SpineTapingParams
 - TrappingDetails
 - TrimmingParams

#	Description	Partition Keys	Comments
1	Select specific Runs in the job.	Run	Allows for the selection of a RunList Run partition by a resource other than RunList. For example, Run="first 3 pages". Whereas the index partitions, BundleItemIndex for example, cannot be named, it must be an IntegerRangeList.
2	Select specific pages in the job.	RunIndex	
3	Select specific documents.	DocIndex	
4	Select specific pages in specific documents.	DocIndex DocRunIndex	
5	Select specific pages in all documents.	DocRunIndex	
6	Select specific bundle items.	BundleItemIndex	
7	Select specific sets in a job.	SetIndex	
8	Select specific documents in specific sets.	SetIndex SetDocIndex	
9	Select specific documents in all sets.	SetDocIndex	
10	Select specific pages in specific sets.	SetIndex SetRunIndex	
11	Select specific pages in all sets.	SetRunIndex	
12	Select specific RunTags.	RunTags	For this application note, only to be used when the PDL supports internal labels and RunTag is implied from the PDL. For this application note, RunTags only refers to labeled documents within the PDL.
13	Select specific pages in the documents that RunTags references.	RunTags DocRunIndex	For this application note, only to be used when the PDL supports internal labels and RunTag is implied from the PDL.

Following are examples of the use of partitioning as supported by this application note:

- 1) Partitioning RunList to define the files or a portion of the file in a job:
 - a) When the aggregate of the files are to be treated as a single entity:

PartIDKeys="Run" is specified in the parent **RunList** resource and **Run="unique identifier"** is specified in each nested child **RunList**.

- b) When the pages of each file are to be referenced with respect to the beginning of each file:
The same as above and in addition **EndOfDocument="true"** is specified for each nested **RunList** child resource.

Note: If **EndOfDocument="true"** is not present for the last nested child **RunList**, even though the default for **EndOfDocument** is "false", the behavior is such that the last nested child **RunList** does include **EndOfDocument** set to "true". As a result, it is treated as the last document and can be referenced using a **DocIndex** partition.

- 2) Partitioning **RunList** to define portions of a job as bundle items so that the individual bundle items can be referenced separately in other resources by partitioning using **BundleItemIndex**. Partitioning **RunList** so that individual bundle item are defined is necessary when insert sheets are included in the **RunList** and the insert sheets are to be finished with all of part of the document or job:

PartIDKeys="Run" is specified in the parent **RunList** resource. **Run="unique bundle item identifier"** and **EndOfBundleItem="true"** are specified in each nested child **RunList**.

There may also be a **EndOfDocument="true"** specified for each nested **RunList** child resource if it is necessary for other resources to partition by **DocIndex**.

Note: If **EndOfBundleItem="true"** is not present for the last nested child **RunList**, even though the default for **EndOfBundleItem** is "false", the behavior is such that the last nested child **RunList** does include **EndOfBundleItem** set to "true". As a result, it is treated as the last bundle item and can be referenced using a **BundleItemIndex** partition.

- 3) Partitioning a resource other than **RunList** to specify that certain pages are to be treated differently:
- a) When specific pages of the job are to be treated differently than the rest of the job:
PartIDKeys="RunIndex" is specified in the parent resource and **RunIndex="list of individual pages and/or page ranges"** is specified in each nested child resource element.
- b) When specific **BundleItems** of the job are to be treated differently than the rest of the job:
PartIDKeys="BundleItemIndex" is specified in the parent resource and **BundleItemIndex="list of individual BundleItems and/or BundleItem ranges"** is specified in each nested child resource element.
- c) When a specific file or portion of a file in the job is to be treated differently than the rest of the job:
PartIDKeys="DocIndex" is specified in the parent resource and **DocIndex="index of document"** is specified in each nested child resource element.
- d) When specific pages of a file or portion of a file in the job are to be treated differently than the rest of the file or job:
PartIDKeys="DocIndex DocRunIndex" is specified in the parent resource, **DocIndex="index of document"** is specified in each nested child resource, and **DocRunIndex="list of individual pages and/or page ranges"** is specified in each resource element that is a nested child of a nested child resource.

An example of 1a) and 3a) would be if specific pages and page ranges are to be printed on the front side of the sheet and the rest of the pages are to be printed on both sides of the sheet.

The **RunList** Resource is partitioned by **Run** so that two files will be included in the job. Note that **EndOfDocument** is not specified for the nested **RunList** child elements, so the pages of the job are an aggregate of the pages of all documents.

The **LayoutPreparationParams** Resource is the Resource that is partitioned. Note that the parent **LayoutPreparationParams** includes **PartIDKeys="RunIndex"** which specifies that partitioning is being done based on the **RunIndex** attribute and that

each child `LayoutPreparationParams` includes page numbers and page ranges as values for its `RunIndex` attribute. Note that the pages referenced by `RunIndex` are the aggregate of the pages in both files, so the page numbers of the second file starts where the page numbers of the first file ends.

```

...
<ResourcePool>
...
  <RunList ID="RunList" Class="Parameter" Status="Available" PartIDKeys="Run" >
    <RunList Run="1" >
      <LayoutElement ID="InputFile1" Class="Parameter" Status="Available" >
        <FileSpec URL="file:///d:/printFile1.ps" />
      </LayoutElement>
    </RunList>
    <RunList Run="2" >
      <LayoutElement ID="InputFile2" Class="Parameter" Status="Available" >
        <FileSpec URL="file:///d:/printFile2.ps" />
      </LayoutElement>
    </RunList>
  </RunList>
  <LayoutPreparationParams ID="LPP" Class="Parameter" Status="Available"
    PartIDKeys="RunIndex" >
    <LayoutPreparationParams RunIndex="5 6 8~12 20~-1" Sides="OneSidedFront" />
    <LayoutPreparationParams RunIndex="0~4 7 13~19" Sides="TwoSidedFlipY" />
  </LayoutPreparationParams>
...
</ResourcePool>
...

```

An example 2), 3b), and 3a) would be if:

- 5 pages are input to the job
- pages 0 through 2 are punched and rotated 90 degrees
- pages 0 through 1 are output to the Top bin
- pages 2 through 4 are stapled and output to the Bottom bin

The `RunList` Resource is partitioned by `Run` so that specific pages in the file are bundled together and referenced as a single entity. Note that `EndOfBundleItem` is specified for the nested `RunList` child elements, so that certain pages of the file will be included in each of the bundles. Each `BundleItem` can be referenced by a 0-based index, where 0 is the first `BundleItem`, 1 is the second `BundleItem`, etc.

The `LayoutPreparationParams` Resource is also partitioned. Note that the parent `LayoutPreparationParams` includes `PartIDKeys="RunIndex"` which specifies that partitioning is being done based on the `RunIndex` attribute and that each child `LayoutPreparationParams` includes page numbers and page ranges as values for its `RunIndex` attribute.

The `DigitalPrintingParams`, `HoleMakingParams`, and `StitchingParams` Resources are partitioned by `BundleItemIndex`. Partitioning by `BundleItemIndex` allows each `BundleItem` to be referenced individually so that attributes can be applied to a `BundleItem` or to multiple `BundleItems`.

ISSUE: Can we make a general statement that `BundleItems` are only used in conjunction with anything when insert sheets are to be included since this is when you would want to "bundle" pages together to perform anything on an entire group of pages that includes insert sheets, such as stapling?

```

...
<ResourcePool>
...
  <RunList PartIDKeys="Run" ComponentGranularity="BundleItem">
    <RunList Run="0" Pages="0~1" EndOfBundleItem="true" >
      <LayoutElement ID="InputFile1" Class="Parameter" Status="Available" >
        <FileSpec URL="file:///d:/printFile1.ps" />
      </LayoutElement>
    </RunList>
  </RunList>
...

```

```

        </LayoutElement>
    </RunList>
    <RunList Run="1" Pages="2" EndOfBundleItem="true" >
        <LayoutElement ID="InputFile1" Class="Parameter" Status="Available" >
            <FileSpec URL="file:///d:/printFile1.ps" />
        </LayoutElement>
    </RunList>
    <RunList Run="2" Pages="3~4" EndOfBundleItem="true" >
        <LayoutElement ID="InputFile1" Class="Parameter" Status="Available" >
            <FileSpec URL="file:///d:/printFile1.ps" />
        </LayoutElement>
    </RunList>
</RunList>

<LayoutPreparationParams ID="LPP" Class="Parameter" Status="Available" PartIDKeys="RunIndex"
    Rotate="Rotate0" >
    <LayoutPreparationParams RunIndex="0~2" Rotate="Rotate90" />
</LayoutPreparationParams>

<DigitalPrintingParams ID="DPP" Class="Parameter" Status="Available"
    PartIDKeys="BundleItemIndex" OutputBin="Top" >
    <DigitalPrintingParams BundleItemIndex="1~2" OutputBin="Bottom" >
</DigitalPrintingParams >

<HoleMakingParams ID="HMP" Class="Parameter" Status="Available" PartIDKeys="BundleItemIndex" >
    <HoleMakingParams BundleItemIndex="0~1" HoleType="R3-generic"/>
</HoleMakingParams>

<StitchingParams ID="SP" Class="Parameter" Status="Available" PartIDKeys="BundleItemIndex" >
    <StitchingParams BundleItemIndex="1~2" StitchType="Corner"/>
</StitchingParams>
...
</ResourcePool>

```

An example of 1b) and 3c) would be if a job contains multiple files that are to be printed where the first file is to be printed on the front side of the sheet and the second file on both sides of the sheet.

The RunList Resource is partitioned by Run so that two files can be included in the job. Note that EndOfDocument is not specified for the nested RunList child elements, so the pages of the job are an aggregate of the pages of all files.

The LayoutPreparationParams Resources is partitioned by DocIndex, so that Sides can be specified for each file. Note that the value of DocIndex refers to the relative position of the file in the RunList.

```

...
<ResourcePool>
    ...
    <RunList ID="RunList" Class="Parameter" Status="Available" PartIDKeys="Run" >
        <RunList Run="1" EndOfDocument="true" >
            <LayoutElement ID="InputFile1" Class="Parameter" Status="Available" >
                <FileSpec URL="file:///d:/printFile1.ps" />
            </LayoutElement>
        </RunList>
        <RunList Run="2" EndOfDocument="true" >
            <LayoutElement ID="InputFile2" Class="Parameter" Status="Available" >
                <FileSpec URL="file:///d:/printFile2.ps" />
            </LayoutElement>
        </RunList>
    </RunList>

```

```

    </RunList>
    <LayoutPreparationParams ID="LPP" Class="Parameter" Status="Available"
      PartIDKeys="DocIndex" >
      <LayoutPreparationParams DocIndex="0" Sides="OneSidedFront" />
      <LayoutPreparationParams DocIndex="1" Sides="TwoSidedFlipY" />
    </LayoutPreparationParams>
    ...
  </ResourcePool>
  ...

```

An example of 1b) and 3d) would be if a job contains multiple files that are to be printed where the first file is to be printed on the front side of the sheet and the second file on both sides of the sheet, except pages 4 and 5 of the second file are to be printed on the back side of the sheet.

The RunList Resource is partitioned by Run so that two files can be included in the job. Note that EndOfDocument="true" is specified for the first nested RunList child element, so the pages for each document can be referenced with respect to the beginning of the document. In this example page 4 and 5 for the second document are the 4th and 5th pages of the second document regardless of the number of pages in the first document.

The LayoutPreparationParams resources is partitioned by DocIndex, so that Sides can be specified for each document. Note that the value of DocIndex refers to the relative position of the document in the RunList.

```

  ...
  <ResourcePool>
  ...
    <RunList ID="RunList" Class="Parameter" Status="Available" PartIDKeys="Run" >
      <RunList Run="1" EndOfDocument="true" >
        <LayoutElement ID="InputFile1" Class="Parameter" Status="Available" >
          <FileSpec URL="file:///d:/printFile1.ps" />
        </LayoutElement>
      </RunList>
      <RunList Run="2" >
        <LayoutElement ID="InputFile2" Class="Parameter" Status="Available" >
          <FileSpec URL="file:///d:/printFile2.ps" />
        </LayoutElement>
      </RunList>
    </RunList>
    <LayoutPreparationParams ID="LPP" Class="Parameter" Status="Available"
      PartIDKeys="DocIndex DocRunIndex" >
      <LayoutPreparationParams DocIndex="0" Sides="OneSidedFront" />
      <LayoutPreparationParams DocIndex="1" Sides="TwoSidedFlipY" />
      <LayoutPreparationParams DocRunIndex="4 5"
        Sides="OneSidedBackFlipY" />
    </LayoutPreparationParams>
  </LayoutPreparationParams>
  ...
</ResourcePool>
...

```

An example of 2), 3b), and 3c) would be if:

- job contains 2 files
- first files is rotated 90 degrees
- pages 0 through 2 of the first files are punched
- an insert sheet is placed before page 2 of the second file
- the insert sheet and pages 2 through 4 of the second file are stapled

The RunList Resource is partitioned by Run so that specific pages in the file are bundled together and referenced as a single entity. Note that EndOfBundleItem is specified for the nested RunList child elements, so that certain pages of the file will be included in each of the bundles. Each BundleItem can be referenced by a 0-based index, where 0 is the first BundleItem, 1 is the second BundleItem, etc.

The LayoutPreparationParams Resource is also partitioned. Note that the parent LayoutPreparationParams includes PartIDKeys="DocIndex" which specifies that partitioning is being done based on the DocIndex attribute and that each child LayoutPreparationParams includes the index of the document as a value for its DocIndex attribute.

The HoleMakingParams and StitchingParams Resources are partitioned by BundleItemIndex. Partitioning by BundleItemIndex allows each BundleItem to be referenced individually so that attributes can be applied to a BundleItem or to multiple BundleItems.

ISSUE: Can we make a general statement that BundleItems are only used in conjunction with Finishing when insert sheets are to be included since this is when you would want to "bundle" pages together to perform finishing on the entire group of pages including the insert sheets?

```

...
<ResourcePool>
...
  <RunList PartIDKeys="Run" ComponentGranularity="BundleItem">
    <RunList Run="0" Pages="0~2" EndOfBundleItem="true" >
      <LayoutElement ID="InputFile1" Class="Parameter" Status="Available" >
        <FileSpec URL="file:///d:/printFile1.ps" />
      </LayoutElement>
    </RunList>
    <RunList Run="1" Pages="3~-1" EndOfDocument="true" EndOfBundleItem="true" >
      <LayoutElement ID="InputFile1" Class="Parameter" Status="Available" >
        <FileSpec URL="file:///d:/printFile1.ps" />
      </LayoutElement>
    </RunList>
    <RunList Run="2" Pages="0 1" EndOfBundleItem="true" >
      <LayoutElement ID="InputFile2" Class="Parameter" Status="Available" >
        <FileSpec URL="file:///d:/printFile2.ps" />
      </LayoutElement>
      <InsertSheet SheetType="InsertSheet" SheetUsage="Header" IsWaste="false" />
    </RunList>
    <RunList Run="3" Pages="2~4" EndOfBundleItem="true" >
      <LayoutElement ID="InputFile2" Class="Parameter" Status="Available" >
        <FileSpec URL="file:///d:/printFile2.ps" />
      </LayoutElement>
      <InsertSheet SheetType="InsertSheet" SheetUsage="Header" IsWaste="false" />
    </RunList>
    <RunList Run="4" Pages="5~-1" EndOfDocument="true" EndOfBundleItem="true" >
      <LayoutElement ID="InputFile2" Class="Parameter" Status="Available" >
        <FileSpec URL="file:///d:/printFile2.ps" />
      </LayoutElement>
    </RunList>
  </RunList>

  <LayoutPreparationParams ID="LPP" Class="Parameter" Status="Available" PartIDKeys="DocIndex"
    Rotate="Rotate0" >
    <LayoutPreparationParams DocIndex="0" Rotate="Rotate90" />
  </LayoutPreparationParams>

  <HoleMakingParams ID="HMP" Class="Parameter" Status="Available"
    PartIDKeys="BundleItemIndex" >

```

```

        <HoleMakingParams BundleItemIndex="0" HoleType="R3-generic"/>
    </HoleMakingParams>

    <StitchingParams ID="SP" Class="Parameter" Status="Available" PartIDKeys="BundleItemIndex" >
        <StitchingParams BundleItemIndex="3" StitchType="Corner"/>
    </StitchingParams>
    ...
</ResourcePool>
...

```

3.1.8.3 Resource References and Partitioning Resources

Following is an example of using both Resource references and partitioned Resources.

Resource references are used to refer to the four LayoutElement resources that identify the files that are part of the job. There are four RunList partitions, each of which contains a reference to a LayoutElement that resides in the ResourcePool.

There are three Media Resources that are referenced by a DigitalPrintingParams resource. The DigitalPrintingParams resource has been partitioned so that the four input files can be printed on media pulled from different input trays.

- The first file is printed using the media in the Top tray.
- The second file is printed using the media in the Middle tray.
- The third file is printed using the media in the Bottom tray.
- The first and last pages of the fourth file are printed using the Top tray.
- The rest of the pages of the fourth file are printed using the Middle tray.

```

.....
<ResourcePool>
    ...
    <LayoutElement ID="InputFile1" Class="Parameter" Status="Available" >
        <FileSpec URL="file:///d:/printFile1.ps" />
    </LayoutElement>
    <LayoutElement ID="InputFile2" Class="Parameter" Status="Available" >
        <FileSpec URL="file:///d:/printFile2.ps" />
    </LayoutElement>
    <LayoutElement ID="InputFile3" Class="Parameter" Status="Available" >
        <FileSpec URL="file:///d:/printFile3.ps" />
    </LayoutElement>
    <LayoutElement ID="InputFile4" Class="Parameter" Status="Available" >
        <FileSpec URL="file:///d:/printFile4.ps" />
    </LayoutElement>
    <RunList ID="RunList" Class="Parameter" Status="Available" PartIDKeys="Run" >
        <RunList Run="1" EndOfDocument="true" >
            <LayoutElementRef rRef="InputFile1" />
        </RunList>
        <RunList Run="2" EndOfDocument="true">
            <LayoutElementRef rRef="InputFile2" />
        </RunList>
        <RunList Run="3" EndOfDocument="true" >
            <LayoutElementRef rRef="InputFile3" />
        </RunList>
        <!-- Note that including EndOfDocument="true" for the following RunList
            is not required since this is the last document in the RunList. -->
        <RunList Run="4" EndOfDocument="true">
            <LayoutElementRef rRef="InputFile4" />
        </RunList>
    </RunList>
</ResourcePool>

```

```

<Media ID="TopTray" Class="Parameter" Status="Available">
  <Location LocationName="top" />
</Media>
<Media ID="MiddleTray" Class="Parameter" Status="Available" >
  <Location LocationName="middle" />
</Media>
<Media ID="BottomTray" Class="Parameter" Status="Available" >
  <Location LocationName="bottom" />
</Media>
<!-- Partition DigitalPrintingParams by both DocIndex and DocRunIndex so that each file in the job and
the pages in each file can be individually referenced -->
<DigitalPrintingParams ID="DPP" Class="Parameter" Status="Available"
  PartIDKeys="DocIndex DocRunIndex">
  <!-- The top tray is the default tray to be used, so it is specified in the parent
DigitalPrintingParams. It will be used by the 1st file in the job since there is not a partition for the
1st file. -->
  <MediaRef rRef="TopTray" />
  <!-- The middle tray will be used to print the file identified by DocIndex="1", which is the 2nd
file. -->
  <DigitalPrintingParams DocIndex="1">
    <MediaRef rRef="MiddleTray" />
  </DigitalPrintingParams>
  <!-- The bottom tray will be used to print the file identified by DocIndex="2", which is the 3rd
file. -->
  <DigitalPrintingParams DocIndex="2">
    <MediaRef rRef="BottomTray" />
  </DigitalPrintingParams>
  <!--The top tray will be used to print the first and last pages of the file identified by DocIndex="3"
and the middle tray will be used to print the rest of the pages in the file.
-->
  <DigitalPrintingParams DocIndex="3">
    <DigitalPrintingParams DocRunIndex="0 -1" >
      <MediaRef rRef="TopTray" />
    </DigitalPrintingParams>
    <DigitalPrintingParams DocRunIndex="1~2" >
      <MediaRef rRef="MiddleTray" />
    </DigitalPrintingParams>
  </DigitalPrintingParams>
</DigitalPrintingParams>
</ResourcePool>
...

```

3.2 Features Supported

This section describes the features that are supported by the Integrated Digital Printing ICS. Each feature has a short description, **Partition Keys**, **Conformance Levels**, **Elements/Resources Used**, **Processes**, **Syntactic Fragment**, and **Allowed Values**.

Features defined in the following sections may be used in combination. For example, even though the Sides and Number Up features are shown as appearing in their own LayoutPreparationParams resources in the following section, they **MUST** be combined in the same LayoutPreparationParams resource as follows:

```

<LayoutPreparationParams ID="Reference ID" Class="Parameter" Status="Available"
  Sides="OneSidedFront" NumberUp="1 2" />

```

Following are descriptions of the headings that appear for each feature:

<p>Partition Keys</p>	<p>For each feature, one or more of the following will appear under the Partition Keys heading:</p> <ul style="list-style-type: none"> • None The resources used by the feature MUST NOT be partitioned. • ResourceName - None <i>ResourceName</i> MUST NOT be partitioned when used for this feature. • RunList - See Table 64 Partitioning RunList The RunList resource MAY be partitioned by the keys listed in the table and MUST NOT be partitioned by any other keys. • ResourceName - See Table 65 Partitioning Resources other than RunList <i>ResourceName</i> MAY be partitioned by the keys listed in the table and MUST NOT be partitioned by any other keys. <p>It is possible that a specific resource that is used for two features MAY be partitioned for one of the features and MUST NOT be partitioned for the other feature. In this case the attributes of the resource that are used for the feature where partitioning is allowed MAY appear a partition, and the attributes of the resource that are used for the feature where partitioning is not allowed MUST NOT appear in a partition.</p>
<p>Elements/Resources Used</p>	<p>Identifies the JDF Elements and Resources that are used by the Feature.</p>
<p>Processes</p>	<p>Identifies the processes to include in the JDF node's Types attribute.</p>
<p>Syntactic Fragment</p>	<p>Shows how the JDF for the feature must appear in a Combined Digital Printing Node.</p> <p>Following are examples of how the syntactic fragment of the feature must appear for various types of partitioning.</p> <p>When no partitioning is specified, the entire job is selected, so the attributes must be specified in the root resource as shown in the following example:</p> <pre><LayoutPreparationParams ID="<i>Reference ID</i>" Class="Parameter" Status="Available" Sides="OneSidedFront" /></pre> <p>To select specific documents in a job, the resource must be partitioned using DocIndex and the attributes must be specified in the partition, as shown in the following example:</p> <p>To specify two sided for all pages in the job, except the second document in the job the is to be printed on the front side:</p> <pre><LayoutPreparationParams ID="<i>Reference ID</i>" Class="Parameter" Status="Available" Sides="TwoSidedFlipY" PartIDKeys="DocIndex" > <LayoutPreparationParams DocIndex="1" Sides="OneSidedFront" /> </LayoutPreparationParams></pre> <p>To select specific pages in a job, where the job consists of one document or there are multiple documents in the job and the pages in the aggregate of the documents are to be treated as a single entity, the resource must be partitioned using RunIndex and the attributes must be specified in the partition, as shown in the following example:</p> <p>To specify two sided for all pages in the job, except pages 6 through 10 which are to be printed on the front side:</p> <pre><LayoutPreparationParams ID="<i>Reference ID</i>" Class="Parameter" Status="Available" Sides="TwoSidedFlipY" PartIDKeys="RunIndex" > <LayoutPreparationParams RunIndex="6-10" Sides="OneSidedFront" /> </LayoutPreparationParams></pre>

	<p>To select specific pages in a specific document in a job, where the job consists of multiple documents and the pages in each document are to be referenced with respect to the beginning of each document, the resource must be partitioned using DocIndex and DocRunIndex and the attributes must be specified in the partition, as shown in the following example:</p> <p>To specify two sides for all pages in the job, except pages 6 through 10 in the second document in the job are to be printed on the front side:</p> <pre> <LayoutPreparationParams ID="Reference ID" Class="Parameter" Status="Available" Sides="TwoSidedFlipY" PartIDKeys="DocIndex DocRunIndex" > <LayoutPreparationParams DocIndex="1" > <LayoutPreparationParams DocRunIndex="6~10" Sides="OneSidedFront" /> </LayoutPreparationParams> </LayoutPreparationParams> </pre>
<p>Allowed Values</p>	<p>Identifies the values that are allowed to be specified for each JDF attribute. The allowed values listed are all of the values that are valid for the Combined Digital Printing Node.</p> <p>The consumer of a Combined Digital Printing Node MUST be able to consume a job ticket that contains any of the allowed values, but the consumer is not required to support the functionality defined by the allowed values.</p>

ISSUE: Should we add a feature that requires or allows a Device to write an element to the AuditPool that indicates that the job has successfully or unsuccessfully completed. See the ProcessRun element. Does this now open up a can of worms because if the Device has to write to the AuditPool then where does the updated ticket go? Does the device then have to write to ticket somewhere?

ISSUE: Should we add a feature, Job ID, that is the JDF Node JobID attribute? 12/12 - Yes, and also add JobPartID, ProjectID, ProductID, and SpawnID since the MIS WG requires these.

ISSUE: Should a Named Feature feature be added?

3.2.1 Approval

Whether or not an approval is required for this job. Can be used to get an approval for a job that is a proof print prior to resubmitting the job for a final print.

Partition Keys

None

Elements/Resources Used

- Address
- ApprovalParams
- ApprovalPerson
- ApprovalSuccess
- ComChannel
- Company
- Contact
- Person
- RenderingParams

Processes

Rendering

Approval**Syntactic Fragment**

```

<RenderingParams ID="Reference ID" Class="Parameter" Status="Available" >
  <ObjectResolution Resolution="device resolution to use" />
</RenderingParams>
<ApprovalParams ID="Reference ID" Class="Parameter" Status="Available"
  <ApprovalPerson>
    <Contact ContactTypes="Approver"
      <Address City="city" Country="country"
        PostBox="post office box"
        PostalCode="zip or postal code"
        Region="state or province"
        Street="street address"
        ExtendedAddress="additional address info" />
      <ComChannel ChannelType="communication type"
        ChannelTypeDetails="details of communication type"
        Locator="communication location" />
      <Company OrganizationName="company/organization name" />
      <Person FirstName="first name"
        FamilyName="family/last name" />
    </Contact>
  </ApprovalPerson>
</ApprovalParams>
<ApprovalSuccess ID="Reference ID" Class="Parameter" Status="Available" />

```

Allowed Values**ID**

String that uniquely identifies the RenderingParams or ApprovalParams.

Resolution

If present, MUST be:

$x \ y$ *Horizontal and vertical resolution, where x and y are in DPI.*

ApprovalPerson

MUST be 1 or more occurrences.

ContactTypes

MUST be set to "Approver".

City

If present, MUST be a String that is the name of the city.

Country

If present, MUST be a String that is the name of the country.

PostBox

If present, MUST be a String that is the post office box (e.g., P.O. Box 101).

PostalCode

If present, MUST be a String that is the zip or postal code.

Region

If present, MUST be a String that is the state or province.

Street

If present, MUST be a String that is the street address.

ExtendedAddress

If present, MUST be a String that is the additional address information (e.g. Suite 245).

ChannelType

MUST be set to one of the following values:

Email	<i>Email address</i>
Fax	<i>Fax number</i>
InstantMessaging	<i>An instant message</i>

JMF	<i>A JMF messaging channel</i>
Phone	<i>Telephone number</i>
PrivateDirectory	<i>Account of a registered customer of a certain service</i>
WWW	<i>WWW home page or form</i>

ChannelTypeDetails

MUST be set to one of the following values:

Landline	<i>Valid when ChannelType is Phone.</i>
Mobile	<i>Valid when ChannelType is Phone.</i>
Secure	<i>Valid when ChannelType is Phone.</i>
ISDN	<i>Valid when ChannelType is Phone.</i>
Target	<i>Valid when ChannelType is WWW to send events to the URL specified in Locator.</i>

Private directory service vendor name

Instant message service vendor name

ISSUE: Should the "Form" value be included in the above list?

Locator

If present, MUST be a String that is the details about how to communicate (e.g. phone number, fax number, email address, URL).

If ChannelType is:	Locator MUST use the form:
Email	Locator="mailto:..." URL [RFC2808].
Fax	Locator="fax:..." URL [RFC2808].
JMF	Locator="http://..." URL [RFC2616].
Phone	Locator="tel:..." URL [RFC2808].
WWW	Locator="http://..." URL [RFC2616].

OrganizationName

If present, MUST be a String that is the name of the company or organization.

FirstName

If present, MUST be a String that is the first name of the contact.

FamilyName

If present, MUST be a String that is the family or last name of the contact.

3.2.2 Billing Code

A code to bill charges incurred.

Partition Keys

None

Elements/Resources Used

CustomerInfo

Processes

None

Syntactic Fragment

<CustomerInfo **BillingCode**="charge code" />

Allowed Values

BillingCode

MUST be a String that is the billing code.

3.2.3 Binding

How to bind the output.

Partition Keys

Component - None
 ComponentLink - None
 CoverApplicationParams and SpineTapingParams- See Table 65 Partitioning Resources other than RunList for the valid partition keys.

Elements/Resources Used

Component
 ComponentLinkCoverApplicationParams
 SpineTapingParams

Processes

SpineTaping
 CoverApplication

Syntactic Fragment

SoftCover

To apply glue to the binding edge of a single sheet that wraps from the front around the binding edge to the back. Also referred to as Perfect binding. An example of this type of binding is a softcover book.

```
<ComponentLink rRef="ID of Component resource"
  Usage="Intermediate" CombinedProcessIndex="index into Types for
  CoverApplication" Orientation="which edge to bind" />
...
<Component ID="Reference ID" ComponentType="PartialProduct" Status="Available" />
<CoverApplicationParams ID="Reference ID" Class="Parameter"
  Status="Available"
  NoOp="whether or not to bind" />
```

Tape

To apply a tape strip along the binding edge to separate front and back covers.

```
<ComponentLink rRef="ID of SpineTapingParams resource"
  Usage="Intermediate" CombinedProcessIndex="index into Types for SpineTaping"
  Orientation="which edge to bind" />
...
<SpineTapingParams ID="Reference ID" Class="Parameter" Status="Available"
  NoOp="whether or not to bind" />
```

Allowed Values

ID

Strings that uniquely identify the Component, SpineTapingParams or CoverApplicationParams.

NoOp

If present, MUST be set to one of the following values:

false	The specified binding is to be performed. This is the default.
true	To turn binding off. No binding is performed. All other binding attributes are ignored.

Component

MUST be present if Orientation is specified.

ComponentLink

MUST be present if Orientation is specified.

ComponentType

MUST be set to "PartialProduct".

CombinedProcessIndex

MUST be an Integer.

Orientation

MUST be present if binding on other than the y-axis is desired. If present, MUST be one of the following values:

Rotate0

Don't rotate the sheet. Binding is to occur on the edge that is along the y-axis (left edge) of the sheet.

Rotate90

Rotate the sheet 90 degrees counter-clockwise. Binding is to occur on the edge that is opposite the x-axis (top edge) of the pre-rotated sheet.

Rotate180

Rotate the sheet 180 degrees. Binding is to occur on the edge that is opposite of the y-axis (right edge) of the pre-rotated sheet.

Rotate270

Rotate the sheet 270 degrees. Binding is to occur on the edge that is along the x-axis (bottom edge) of the pre-rotated sheet.

Flip0

Do not rotate the sheet, flip the sheet around the x-axis. Binding is to occur on the edge that is along the y-axis (left edge) of the pre-flipped sheet.

Flip90

Rotate the sheet 90 degrees counter-clockwise and flip around the x-axis. Binding is to occur on the edge that is opposite the x-axis (top edge) of the pre-rotated/flipped sheet.

Flip180

Rotate the sheet 180 degrees and flip around the x-axis. Binding is to occur on the edge that is opposite of the y-axis (right edge) of the pre-rotated/flipped sheet.

Flip270

Rotate the sheet 270 degrees counter-clockwise and flip around the x-axis. Binding is to occur on the edge that is along the x-axis (bottom edge) of the pre-rotated/flipped sheet.

Usage

MUST be set to "Intermediate".

3.2.4 Black Overprint

Automated selection of overprint for black text and/or graphics.

Partition Keys

AutomatedOverPrintParams - None

RenderingParams - See Table 65 Partitioning Resources other than RunList for the valid partition keys.

Elements/Resources Used

AutomatedOverPrintParams

RenderingParams

Processes

Rendering

Syntactic Fragment

```
<RenderingParams ID="Reference ID" Class="Parameter" Status="Available" >
  <AutomatedOverPrintParams OverPrintBlackText="whether to overprint black text"
    OverPrintBlackLineArt="whether to overprint black graphics" />
</RenderingParams>
```

Allowed Values

ID

String that uniquely identifies the RenderingParams.

OverPrintBlackText

If present, MUST be set to one of the following values:

- false This is the default.
- true

OverPrintBlackLineArt

If present, MUST be set to one of the following values:

- false This is the default.
- true

3.2.5 Collate

Whether the sheets in the documents and the documents in the job should be collated when multiple copies of the job are requested.

Partition Keys

None

Elements/Resources Used

DigitalPrintingParams

Processes

DigitalPrinting

Syntactic Fragment

```
<DigitalPrintingParams ID="Reference ID" Class="Parameter" Status="Available"
  Collate="whether to collate or not" />
```

Allowed Values

ID

String that uniquely identifies the DigitalPrintingParams.

Collate

MUST be set to one of the following values:

- None *Do not collate.*
- Sheet *Collate the sheets in the documents in the job.*
- SheetSetAndJob *Collate the sheets in the documents, documents in the sets, and the sets in the job.*
- SheetAndSet *Collate the sheets in the sets in the job.*

Example: A job contains 2 documents, A and B, each have 2 sheets, A1, A2, and B1, B2. The number of job copies requested is 3.

If Collate=None, the sheet order will be: A1A1A1 A2A2A2 B1B1B1 B2B2B2

If Collate=Sheet the sheet order will be: A1A2 A1A2 A1A2 B1B2 B1B2 B1B2

If Collate=SheetSetAndJob, the sheet order will be: A1A2B1B2 A1A2B1B2 A1A2B1B2

3.2.6 Comment/Description of Job

A comment that describes the job and will be carried along with the job. This information is about the job not the job ticket template. Use the Job Ticket Template Comment or Description to include a description of the job ticket template.

This comment MUST only be present in the root JDF Node. If the Combined Digital Printing Node is the root JDF Node, then this comment appears in the Combined Digital Printing Node. If the Combined Digital Printing Node is not the root JDF node, then if present this comment MUST appear in the root JDF Node and not the child Combined Digital Printing Node.

Partition Keys

None

Elements/Resources Used

JDF (Combined Digital Printing Node)
Comment

Processes

None

Syntactic Fragment

```
<JDF ID=... Type="Combined" Types=... Status="Ready"
  <Comment Language="language code or language and country code "
    Name="JobDescription"> comment or description text </Comment>
...>
```

Allowed Values

Name

Always set to JobDescription.

comment or description text

MUST be a String that contains a comment about or a description of the Combined Digital Printing Node.

Language

If present, MUST be set to contain either a language code in the form "en" or a language and country code in the form "en-US".

3.2.7 Contact Information

Contact information for the job.

Partition Keys

None

Elements/Resources Used

Address
ComChannel
Company
Contact
CustomerInfo
Person

Processes

None

Syntactic Fragment

```
<CustomerInfo
  <Contact ContactTypes="classification of contact" >
    <Address City="city" Country="country" PostBox="post office box"
      PostalCode="zip or postal code" Region="state or province"
      Street="street address" ExtendedAddress="additional address info"
    />
    <ComChannel ChannelType="communication type"
      ChannelTypeDetails="details of communication type"
      Locator="communication location" />
    <Company OrganizationName="company/organization name" />
    <Person FirstName="first name" FamilyName="family/last name" />
  </Contact>
```

</CustomerInfo>

Allowed Values

ContactTypes

MUST be set to one of the following values:

Administrator
Accounting
Approver
Customer
Delivery
Owner
Pickup
Sender
Supplier
SurplusReturn
ArtReturn

City

If present, MUST be a String that is the name of the city.

Country

If present, MUST be a String that is the name of the country.

PostBox

If present, MUST be a String that is the post office box (e.g. P.O. Box 101).

PostalCode

If present, MUST be a String that is the zip or postal code.

Region

If present, MUST be a String that is the state or province.

Street

If present, MUST be a String that is the street address.

ExtendedAddress

If present, MUST be a String that is the additional address information (e.g. Suite 245).

ChannelType

MUST be set to one of the following values:

Email	<i>Email address.</i>
Fax	<i>Fax number.</i>
InstantMessaging	<i>An instant message</i>
JMF	<i>A JMF messaging channel</i>
Phone	<i>Telephone number.</i>
PrivateDirectory	<i>Account of a registered customer of a certain service</i>
WWW	<i>WWW home page or form.</i>

ChannelTypeDetails

MUST be set to one of the following values:

Landline	<i>Valid when ChannelType is Phone.</i>
Mobile	<i>Valid when ChannelType is Phone.</i>
Secure	<i>Valid when ChannelType is Phone.</i>
ISDN	<i>Valid when ChannelType is Phone.</i>
Target	<i>Valid when ChannelType is WWW to send events to the URL specified in Locator.</i>
	<i>Private directory service vendor name</i>
	<i>Instant message service vendor name</i>
	ISSUE: Should the "Form" value be included in the above list?

Locator

If present, MUST be a String that is the details about how to communicate (e.g. phone number, fax number, email address, URL).

If ChannelType is:

Locator MUST use the form:

Email

Locator="mailto:..." URL [RFC2808].

Fax	Locator="fax:.." URL [RFC2808].
JMF	Locator="http://..." URL [RFC2616].
Phone	Locator="tel:.." URL [RFC2808]
WWW	Locator="http://..." URL [RFC2616].
OrganizationName	
	If present, MUST be a String that is the name of the company or organization.
FirstName	
	If present, MUST be a String that is the first name of the contact.
FamilyName	
	If present, MUST be a String that is the family or last name of the contact.

3.2.8 Covers

There are two ways to include covers with a job. One, the content that is to be imaged on the covers is not included in the job, the covers are either blank or preprinted. Two, the content that is to be imaged on the covers is included in the job. For the first case, see Insert Sheet on 99 page. For the second case, the following description explains how different media can be specified for the front cover, back cover, and the document body.

Print front and/or back covers with the job, where the first one or two pages and/or the last one of two pages of the job contains the content of the front and/or back covers.

Partition Keys

InsertSheet - None
 LayoutElement - None
 All ResourceRef - None
 LayoutPreparationParams - See Table 65 Partitioning Resources other than RunList for the valid partition keys.
 Media - See Table 65 Partitioning Resources other than RunList for the valid partition keys.
 RunList - See Table 64 Partitioning RunList for the valid partition keys.

Elements/Resources Used

InsertSheet
 LayoutElement
 All ResourceRef
 LayoutPreparationParams
 Media
 MediaRef
 RunList

Processes

LayoutPreparation

Syntactic Fragment

```
<Media ID="Front cover media reference ID" Class="Consumable" Status="Available" />
<Media ID="Back cover media reference ID" Class="Consumable" Status="Available" />
<Media ID="Document body media reference ID" Class="Consumable"
  Status="Available" />
<LayoutPreparationParams ID="LayoutPreparationParams reference ID" Class="Parameter"
  Status="Available" PartIDKeys="DocIndex RunIndex | DocRunIndex" >
  <LayoutPreparationParams
    DocIndex="index of document or part of document"
    <!-- Sides and Media for front cover -->
    <LayoutPreparationParams RunIndex | DocRunIndex="0" | "0 1"
      Sides="sides to print front cover on" />
  </LayoutPreparationParams>
```



```

<!-- Sides and Media for document body -->
<LayoutPreparationParams
  RunIndex | DocRunIndex="1~2" | "1~3" | "2~2" | "2~3"
  Sides="sides to print document body on" />
<!-- Sides and Media for back cover -->
<LayoutPreparationParams RunIndex | DocRunIndex="-1" | "-2 -1"
  Sides="sides to print back cover on" />
</LayoutPreparationParams>

<!-- Take the case where the media for the front and back covers is the same as the media for the
body of the document and the entire document (covers and body) is to be printed two
sided. The body of the document could end on the front side of a sheet, which would mean that the
front side of the back cover would print on the back side of the last sheet of the body of the
document. The following will force the back side of the last sheet of the body of the document to
be blank if the body of the document ends on the front side of the sheet by conditionally inserting
a fill sheet. If the body of the document ends on the back side of the sheet, then a fill sheet is not
inserted because the front side of the back cover will already be printed on the next sheet. -->
<LayoutElement ID="LayoutElement reference ID" Class="Parameter" Status="Available" >
  <FileSpec URL="document file name" />
</LayoutElement>
<RunList ID="RunList reference ID" Class="Parameter" Status="Available"
  PartIDKeys="Run">
  <!-- The following will insert a sheet before the third to the last page if necessary. -->

  <RunList Run="document's page range Run value" Pages="0~3">
    <LayoutElementRef rRef="LayoutElement reference ID" />
  </RunList>
  <!-- Include the last two pages which will be the back cover. -->
  <RunList Run="document's page range Run value" Pages="-2 -1">
    <LayoutElementRef rRef="LayoutElement reference ID" />
    <InsertSheet SheetType="FillSheet" SheetUsage="FillForceFront"
      SheetFormat="Blank" IsWaste="false" />
  </RunList>
</RunList>

```

Allowed Values

ID	String that uniquely identify the Media, LayoutPreparationParams, and RunList.
rRef	Strings that reference the Media, LayoutPreparationParams, and RunList by means of their unique IDs.
Run	String that uniquely identifies a specific partition of the RunList.
DocIndex	If present, MUST be the Index of document being referenced. Specify DocIndex and DocRunIndex to reference the pages in an individual document.
RunIndex or DocRunIndex	Specify RunIndex to reference the pages in the job and DocRunIndex to reference the pages in an individual document.
0	First page. Use for first RunIndex/DocRunIndex for one-sided front cover.
-1	Last page. Use for third RunIndex/DocRunIndex for one-sided back cover.
0 1	First two pages. Use for first RunIndex/DocRunIndex for two-sided front cover.
-2 -1	Last two pages. Use for third RunIndex/DocRunIndex for two-sided back cover.

- 1~2 *Second through second to the last pages. Use for second RunIndex/DocRunIndex for document body when front and back covers are one-sided.*
- 1~3 *Second through third to the last pages. Use for second RunIndex/DocRunIndex for document body when front cover is one-sided and back cover is two-sided.*
- 2~2 *Third through second to the last pages. Use for second RunIndex/DocRunIndex for document body when front cover is two-sided and back cover is one-sided.*
- 2~3 *Third through third to the last pages. Use for second RunIndex/DocRunIndex for document body when front and back covers are two-sided.*

Sides

MUST be set to one of the following values:

- OneSidedBackFlipX** *Image on back side of the media where the page content is placed such that binding can occur along the x-axis. This is equivalent to tumble.*
- OneSidedBackFlipY** *Image on back side of the media where the page content is placed such that binding can occur along the y-axis.*
- OneSidedFront** *Image on front side of the media. This is the default.*
- TwoSidedFlipX** *Image on front and back sides of media where the page content is placed such that binding can occur along the x-axis. This is equivalent to tumble.*
- TwoSidedFlipY** *Image on front and back sides of media where the page content is placed such that binding can occur along the y-axis.*

URL

MUST be set to the location of the document. See Document File Name on page 87 for usage notes.

Pages

MUST be set to "0~3" for the first occurrence of Pages and "-2 -1" for the second.

SheetType

MUST be set to "FillSheet".

SheetUsage

MUST be set to "FillForceFront".

SheetFormat

MUST be set to "Blank".

IsWaste

MUST be set to "false".

Note: Valid combinations of Pages and Sides are:

- 0 and OneSidedFront to print the first page on the front side of the front cover.
- 0 and OneSidedBackFlipX or OneSidedBackFlipY to print the first page on the back side of the front cover.
- -1 and OneSidedBackFlipX or OneSidedBackFlipY to print the last page on the back side of the back cover.
- -1 and OneSidedFront to print last page on the front side of the back cover.
- 0 1 and TwoSidedFlipX or TwoSidedFlipY to print the first two pages on the front and back sides of the front cover.
- -2 -1 and TwoSidedFlipX or TwoSidedFlipY to print the last two pages on the front and back sides of the back cover.
- 1~2, 1~3, 2~2, 2~3, and any value of Sides to print the body of the document as specified by Sides.

3.2.9 Destination or Physical Printer Requested

Printer or destination device that is to execute the Combined Digital Printing Node. .

Partition Keys

None.

Elements/Resources Used

Device

NodeInfo

Processes

None

Syntactic Fragment

```
<NodeInfo Route="URL of device"
...
<Device ID="Reference ID" Class="Implementation" Status="Available" >
  DeviceID="name or ID of device"
  Manufacturer="manufacturer of device"
  ModelNumber="model number of device" />
</Device>
```

Allowed Values

ID

String that uniquely identifies the Device.

DeviceID

String that identifies the device.

Manufacturer

If present, MUST be a String that identifies the manufacturer of the device.

ModelNumber

If present, MUST be a String that identifies the model number of the device.

Route

Optional. URL of device.

3.2.10 Destination or Physical Printer Resolution

Resolution that the destination or physical printer is to use in the horizontal (cross-feed) and vertical (feed) directions in units of DPI.

Partition Keys

ObjectResolution - None

RenderingParams - See Table 65 Partitioning Resources other than RunList for the valid partition keys.

Elements/Resources Used

ObjectResolution

RenderingParams

Processes

Rendering

Syntactic Fragment

```
<RenderingParams ID="Reference ID" Class="Parameter" Status="Available" >
  <ObjectResolution Resolution="device resolution to use" />
</RenderingParams>
```

Allowed Values**ID**

String that uniquely identifies the RenderingParams.

Resolution

MUST be set where:

x y *Horizontal and vertical resolution where x and y are in DPI.*

3.2.11 Document Compression

ISSUE: Should this feature be renamed File Compression?

Compression algorithm to use to compress or encoding to use to encode the document data.

Partition Keys

FileSpec - None

LayoutElement - None

All ResourceRef - None

RunList - See Table 64 Partitioning RunList for the valid partition keys.

Elements/Resources Used

FileSpec

LayoutElement

All ResourceRef

RunList

Processes

LayoutPreparation

Syntactic Fragment

For jobs that contain a single document (file):

```
<LayoutElement ID="LayoutElement reference ID" Class="Parameter"
  Status="Available" >
  <FileSpec Compression="compression algorithm to use" />
</LayoutElement>
<RunList ID="RunList reference ID" Class="Parameter" Status="Available" >
  <LayoutElementRef rRef="LayoutElement reference ID" />
</RunList>
```

For jobs that contain multiple documents (files):

```
<LayoutElement ID="LayoutElement 1 reference ID" Class="Parameter"
  Status="Available" >
  <FileSpec Compression="compression algorithm to use" /></LayoutElement>
<LayoutElement ID="LayoutElement 2 reference ID" Class="Parameter"
  Status="Available" >
  <FileSpec Compression="compression algorithm to use" />
</LayoutElement>
<RunList ID="RunList reference ID" Class="Parameter" Status="Available"
  PartIDKeys="Run" >
  <RunList Run="document's Run value" >
    <LayoutElementRef rRef="LayoutElement 1 reference ID" />
  </RunList>
  <RunList Run="document's Run value" >
    <LayoutElementRef rRef="LayoutElement 2 reference ID" />
  </RunList>
</RunList>
```

ISSUE: Add FileSpec/Container to be used when Compression is not None.

Allowed Values**ID**

String that uniquely identifies the LayoutElement.

Run

String that uniquely identifies a specific partition of the RunList.

Compression

MUST be set to one of the following values:

None *Do not compress. This is the default.*
 Base64
 BinHex
 Compress
 Deflate
 Gzip
 MacBinary
 UUEncode
 ZLIB

3.2.12 Document File Format

ISSUE: Should this feature be renamed File Format?

Identifies the format of the data in the document in a job.

Partition Keys

FileSpec - None

LayoutElement - None

All ResourceRef - None

RunList - See Table 64 Partitioning RunList for the valid partition keys.

Elements/Resources Used

FileSpec

LayoutElement

All ResourceRef

RunList

Processes

LayoutPreparation

Syntactic Fragment

For jobs that contain a single document (file):

```
<LayoutElement ID="LayoutElement reference ID" Class="Parameter"
  Status="Available" >
  <FileSpec MimeType="data file format" MimeTypeVersion="version or level of data file
format" />
</LayoutElement>
<RunList ID="RunList reference ID" Class="Parameter" Status="Available" >
  <LayoutElementRef rRef="LayoutElement reference ID" />
</RunList>
```

For jobs that contain multiple documents (files):

```
<LayoutElement ID="LayoutElement 1 reference ID" Class="Parameter"
  Status="Available" >
  <FileSpec MimeType="data file format" MimeTypeVersion="version or level of data file
format" />
</LayoutElement>
<LayoutElement ID="LayoutElement 2 reference ID" Class="Parameter"
```

```

    Status="Available" >
    <FileSpec MimeType="data file format" MimeTypeVersion="version or level of data file
    format"/>
  </LayoutElement>
  <RunList ID="RunList reference ID" Class="Parameter" Status="Available"
  PartIDKeys="Run" >
    <RunList Run="document's Run value" >
      <LayoutElementRef rRef="LayoutElement 1 reference ID" />
    </RunList>
    <RunList Run="document's Run value" >
      <LayoutElementRef rRef="LayoutElement 2 reference ID" />
    </RunList>
  </RunList>
</RunList>

```

Allowed Values

ID

Strings that uniquely identify the LayoutElement and RunList.

rRef

Strings that reference the LayoutElement and RunList by means of their unique IDs.

Run

String that uniquely identifies a specific partition of the RunList.

MimeType

Following are examples of values that may be supported (see [JDF] Appendix P):

```

application/pdf
application/postscript
application/octet-stream (supported by devices that are capable of auto-sensing the
format)
application/vnd.hp-PCL
application/vnd.podi-ppml+xml
ICC Profile
image/jpg
image/tiff
multipart/related
text/plain

```

MimeTypeVersion

MUST be a String that identifies the version of the MimeType. Following are examples of values that may be supported:

```

PS/1
PS/2
PS/3
PCL/3
PCL/4
PCL/5
PCL/5e
PCL/6
PCL/X
PDF/1.0
PDF/1.1
PDF/1.2
PDF/1.3
PDF/1.4
PDF/1.5
PDF/1.6
PDF/X-1a:2001
PDF/X-3:2002
PDF/X-1a:2003

```

PDF/X-3:2003
 PDF/X-2:2003
 PDF/PPML/VDX-2002
 PDF/is-1.0
 ICC-Profile/2.1.0
 ICC-Profile/2.2.0
 ICC-Profile/2.4.0
 ICC-Profile/4.0.0
 PPML/1.5
 PPML/1.5
 PPML/2.0
 PPML/2.1
 tiff/6.0

3.2.13 Document File Name

ISSUE: Should this feature be renamed File Name?

Name of the document (file) in a job.

Partition Keys

FileSpec - None
 LayoutElement - None
 All ResourceRef - None
 RunList - See Table 64 Partitioning RunList for the valid partition keys.

Elements/Resources Used

FileSpec
 LayoutElement
 All ResourceRef
 RunList

Processes

LayoutPreparation

Syntactic Fragment

For jobs that contain a single document (file):

```

<LayoutElement ID="LayoutElement reference ID" Class="Parameter"
  Status="Available" >
  <FileSpec
    Directory="directory where file resides"
    URL="file name" />
  </LayoutElement>
<RunList ID="RunList reference ID" Class="Parameter" Status="Available"
  <LayoutElementRef rRef="LayoutElement reference ID" />
</RunList>

```

For jobs that contain multiple documents (files):

```

<LayoutElement ID="LayoutElement 1 reference ID" Class="Parameter"
  Status="Available" >
  Directory="directory where file 1 resides"
  <FileSpec URL="document 1 file name" />
</LayoutElement>
<LayoutElement ID="LayoutElement 2 reference ID" Class="Parameter"
  Status="Available" >
  Directory="directory where file 2 resides"
  <FileSpec URL="document 2 file name" />

```

```

</LayoutElement>
<RunList ID="RunList reference ID" Class="Parameter" Status="Available"
  PartIDKeys="Run" >
  <RunList Run="document's Run value" EndOfDocument=
    "whether of not document is to be treated separately" >
    <LayoutElementRef="LayoutElement 1 reference ID" />
  </RunList>
  <RunList Run="document's Run value" EndOfDocument=
    "whether of not document is to be treated separately" >
    <LayoutElementRef="LayoutElement 2 reference ID" />
  </RunList>
</RunList>

```

Allowed Values

ID

Strings that uniquely identify the LayoutElement and RunList.

rRef

Strings that reference the LayoutElement and RunList by means of their unique IDs.

Directory

If present, MUST be a URL that identifies where the file resides.

EndOfDocument

MUST be set to one of the following values:

- false
- true

Run

String that uniquely identifies a specific partition of the RunList.

URL

MUST be set as the location of the file in the form as specified in [URL-AppNote]. URL="" can be specified when imbedding a JDF job ticket in a PPML file (MimeType="application/vnd.podi-ppml+xml"). Use of URL="" for any other MimeType does not conform to this application note because it requires a private agreement between the Controller/Agent and Device.

The following URL schemes must be supported:

- cid:
- file:
- http:

The following URL schemes may be supported:

- ftp:
- https:

3.2.14 Document Natural Language

ISSUE: Should this feature be renamed File Natural Language?

The natural language of the document (file) in a job.

Partition Keys

- FileSpec - None
- LayoutElement - None
- All ResourceRef - None
- RunList - See Table 64 Partitioning RunList for the valid partition keys.

Elements/Resources Used

- FileSpec
- LayoutElement

All ResourceRef
RunList

Processes

LayoutPreparation

Syntactic Fragment

For jobs that contain a single document (file):

```
<LayoutElement ID="LayoutElement reference ID" Class="Parameter"
  Status="Available" >
  <FileSpec DocumentNaturalLanguage="data format" />
</LayoutElement>
<RunList ID="RunList reference ID" Class="Parameter" Status="Available" >
  <LayoutElementRef rRef="LayoutElement reference ID" />
</RunList>
```

For jobs that contain multiple documents (files):

```
<LayoutElement ID="LayoutElement 1 reference ID" Class="Parameter"
  Status="Available" >
  < DocumentNaturalLanguage="data format" />
</LayoutElement>
<LayoutElement ID="LayoutElement 2 reference ID" Class="Parameter"
  Status="Available" >
  <FileSpec DocumentNaturalLanguage="data format" />
</LayoutElement>
<RunList ID="RunList reference ID" Class="Parameter" Status="Available"
  PartIDKeys="Run" >
  <RunList Run="document's Run value" >
    <LayoutElementRef rRef="LayoutElement 1 reference ID" />
  </RunList>
  <RunList Run="document's Run value" >
    <LayoutElementRef rRef="LayoutElement 2 reference ID" />
  </RunList>
</RunList>
```

Allowed Values

ID

String that uniquely identifies the RunList.

Run

String that uniquely identifies a specific partition of the RunList.

DocumentNaturalLanguage

MUST be a String that represents either a language in the form “en” or a language and country code in the form “en-US”. If not specified defaults to system specified.

3.2.15 Feed Orientation

Specifies the media edge which is to be fed into the device from the paper tray. [JDF] specifies that the feed direction is such that the paper travels along the Y-axis starting at Y=0, so the X-axis is the leading edge.

ISSUE: Should we remove the Feed Orientation feature from the first release of the ICS for DP because we still have questions about it and the coordinate system?

Partition Keys

None

Elements/Resources Used

MediaLink

Processes

DigitalPrinting

Syntactic Fragment

There are two ways that the feed direction can be changed.

1. Swap the x and y dimensions of the media. For example, if typically x is 612 points and y is 792 points, then the short (612 point) edge will be the leading edge. To make the leading edge, the long (792 point) edge, make the x dimension 792 points and the y dimension 612 points.

See Media for a description of how to specify Media Dimensions.

2. Specify that the media is to be rotated and or flipped in the MediaLink.

```
<MediaLink rRef="ID of media resource" Usage="Input"
  CombinedProcessIndex="index of Digital Printing process"
  Orientation="value description" />
```

Allowed Values

ID

String that uniquely identifies the *ResourceName*.

Orientation

MUST be set to one of the following values:

Rotate0	<i>Do not rotate media.</i>
Rotate90	<i>Rotate media 90 degrees counter-clockwise.</i>
Rotate180	<i>Rotate media 180 degrees.</i>
Rotate270	<i>Rotate media 90 degrees clockwise.</i>
Flip0	<i>Flip media vertically.</i>
Flip90	<i>Rotate media 90 degrees clockwise and flip horizontally.</i>
Flip180	<i>Flip media horizontally.</i>
Flip270	<i>Rotate media 90 degrees counter-clockwise and flip horizontally.</i>

3.2.16 Fit Policy

What to do when the page content does not fit on the media.

Partition Keys

FitPolicy - None

ImageShift - None

LayoutPreparationParams - See Table 65 Partitioning Resources other than RunList for the valid partition keys.

Elements/Resources Used

FitPolicy

ImageShift

LayoutPreparationParams

Processes

LayoutPreparation

Syntactic Fragment

```
<LayoutPreparationParams ID="Reference ID" Class="Parameter" Status="Available" >
  <FitPolicy SizePolicy="what to do when content doesn't fit"
    RotatePolicy="how to rotate when content doesn't fit" />
```

```

<ImageShift
  PositionX="how to horizontally position the content"
  PositionY="how to vertically position the content" />
</LayoutPreparationParams>

```

Allowed Values

ID

String that uniquely identifies the LayoutPreparationParams.

RotatePolicy

If present, MUST be set to one of the following values:

NoRotate	Do not rotate.
RotateOrthogonal	Rotate by 90° in either direction, i.e., rotate if necessary to fit.
RotateClockwise	Rotate clockwise by 90°.
RotateCounterClockwise	Rotate counter-clockwise by 90°.

SizePolicy

If present, MUST be set to one of the following values:

Abort	Emit an error and abort printing.?
ClipToMaxPage	The page contents should be clipped to the size of the container. The printed area is either centered in the source image.
FitToPage	The page contents should be scaled up or down to fit the media. The aspect ratio is maintained.
ReduceToFit	The page contents should be scaled down but not scaled up to fit the media. The aspect ratio is maintained.
Tile	The page contents should be split into several tiles, each printed on its own surface.

PositionX

If present, MUST be set to one of the following values:

Center	Center the contents horizontally without regard to the limitations of the media's printable area.
Left	Position the left edge of the contents to be coincident with the left edge of the media's printable area.
Right	Position the right edge of the contents to be coincident with the right edge of the media's printable area.
None	Place the contents where the print data specifies.

PositionY

If present, MUST be set to one of the following values:

Bottom	Position the bottom edge of the contents to be coincident with the bottom edge of the media's printable area.
Center	Center the contents vertically without regard to the limitations of the media's printable area.
Top	Position the top edge of the contents to be coincident with the top edge of the media's printable area.
None	Place the contents where the print data specifies.

3.2.17 Folding

How to fold the output.

Partition Keys

Component - None

ComponentLink - None

FoldingParams - See Table 65 Partitioning Resources other than RunList for the valid partition keys.

Elements/Resources Used

Component

ComponentLink
FoldingParams

Processes

Folding

Syntactic Fragment

```

<ComponentLink rRef="ID of Component resource"
  Usage="Intermediate" CombinedProcessIndex="index into Types for Folding"
  Orientation="which edge to fold" />
...
<Component ID="Reference ID" ComponentType="PartialProduct" Status="Available" />
<FoldingParams ID="Reference ID" Class="Parameter" Status="Available" >
  NoOp="whether or not to fold"
  FoldCatalog="type of folding operation to perform"

```

Allowed Values

ID

String that uniquely identifies the FoldingParams.

NoOp

If present, MUST be set to one of the following boolean values:

- false To use other FoldingParams attributes to specify folding. This is the default.
- true To turn folding off. All other FoldingParams attributes are ignored.

FoldCatalog

MUST be set to one of the following values to specify the type of fold operation to perform:

- F4-1 perform a saddle-fold operation. This fold is used for booklets.
- F6-2 perform a z-fold in thirds operation. This fold is used for brochures.
- F6-4 perform a c-fold operation
- F6-6 perform a z-fold operation. The result of the F6-6 z-fold is such that the sheet is face down. If the desired result is that the sheet be face up, then set Orientation="Flip180" in the Intermediate ComponentLink.

Component

MUST be present if Orientation is specified.

ComponentLink

MUST be present if Orientation is specified.

ComponentType

MUST be set to "PartialProduct".

CombinedProcessIndex

MUST be an Integer.

Orientation

MUST be present if folding on other than the y-axis is desired. If present, MUST be one of the following values:

- Rotate0 Don't rotate the sheet. Folding is to occur from the edge that is along the y-axis (left edge) of the sheet.
- Rotate90 Rotate the sheet 90 degrees counter-clockwise. Folding is to occur from the edge that is opposite the x-axis (top edge) of the pre-rotated sheet.
- Rotate180 Rotate the sheet 180 degrees. Folding is to occur from the edge that is opposite of the y-axis (right edge) of the pre-rotated sheet
- Rotate270 Rotate the sheet 270 degrees. Folding is to occur from the edge that is along the x-axis (bottom edge) of the pre-rotated sheet.

Flip0	<i>Do not rotate the sheet, flip the sheet around the x-axis. Folding is to occur from the edge that is along the y-axis (left edge) of the pre-flipped sheet.</i>
Flip90	<i>Rotate the sheet 90 degrees counter-clockwise and flip around the x-axis. Folding is to occur from the edge that is opposite the x-axis (top edge) of the pre-rotated/flipped sheet.</i>
Flip180	<i>Rotate the sheet 180 degrees and flip around the x-axis. Folding is to occur from the edge that is opposite of the y-axis (right edge) of the pre-rotated/flipped sheet.</i>
Flip270	<i>Rotate the sheet 270 degrees counter-clockwise and flip around the x-axis. Folding is to occur from the edge that is along the x-axis (bottom edge) of the pre-rotated/flipped sheet.</i>
Usage	MUST be set to "Intermediate".

3.2.18 Force Page

Force the next page after the specified range of pages on either the front or back side of the sheet. This feature can be used to ensure that chapters will start on a specific side of the sheet and is only honored when two-sided printing is specified.

Partition Keys

InsertSheet - None
 RunList - See Table 64 Partitioning RunList for the valid partition keys.

Elements/Resources Used

InsertSheet
 RunList

Processes

LayoutPreparation

Elements/Resources Used

InsertSheet
 LayoutElement
 RunList

Syntactic Fragment

```
<RunList ID="RunList reference ID" Class="Parameter" Status="Available"
  PartIDKeys="Run">
  <!-- The following will insert a sheet after the last page of the specified page range so
  that the next page after the page range will print on the desired side of the sheet. -->
  <RunList Run="document's page range Run value"
    Pages="range of pages before forcing a new sheet">
    <LayoutElementRef rRef="LayoutElement reference ID" />
    <InsertSheet SheetType="FillSheet"
      SheetUsage="whether to force to back or front side" SheetFormat="Blank"
      IsWaste="false" />
  </RunList>
  ... Include as many partitioned RunLists here as needed in the form as shown above.
  ... There should be one for each page range after which the next page will be forced
  ... to print on the specified side.
  <!-- The last page range is for the end of the document. -->
  <RunList Run="document's page range Run value"
```

```

    Pages="last page range of document" >
    <LayoutElementRef rRef="LayoutElement reference ID" />
  </RunList>
</RunList>

```

Allowed Values

ID

String that uniquely identifies the RunList.

rRef

String that references the RunList by means of its unique.

Run

String that uniquely identifies a specific partition of the RunList.

Pages

MUST be set, where:

x~y Range of pages that are to occur before forcing a new sheet. The last page range begins with the last page to force to a specific side through the end of the document (-1).

SheetType

MUST be set to "FillSheet".

SheetUsage

MUST be set to one of the following values:

FillForceBack

Use to fill the front surface of the current sheet (sheet 0) so that the next page (page 0) will be imaged on the back surface of the current sheet (sheet 0) if the next page (page 0) would not have already been imaged on the back surface, as follows:

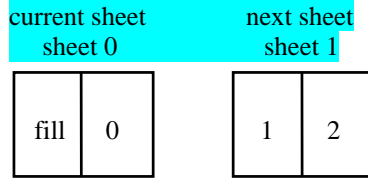

```

<RunList PartIDKeys=Run" ...>
  <RunList Run="0" Pages="0" ...>
    <InsertSheet SheetUsage="FillForceBack" .../>
  </RunList>
  <RunList Run="1" Pages="1 2" .../>
</RunList>

```

FillForceFront

Use to fill the back surface of the current sheet (sheet 0) so that the next page (page 1) will be imaged on the front surface of the next sheet (sheet 1) if the next page (page 1) would not have already been imaged on the back surface, as follows:

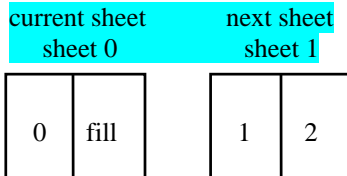

```

<RunList PartIDKeys=Run" ...>
  <RunList Run="0" Pages="0" .../>
  <RunList Run="1" Pages="1 2" .../>
  <InsertSheet SheetUsage="FillForceFront" .../>

```

```

        </RunList>
    </RunList>
    SheetFormat
        MUST be set to "Blank".
    IsWaste
        MUST be set to "false".
    
```

Example: When printing two sided, to ensure that page 0 is printed on the back side of a sheet and pages 3 and 6 are printed on the front side of a sheet, set SheetUsage to FillForceFront, and partition the RunList as follows:

```

<RunList PartIDKeys=Run" ...>
  <RunList Run="0" Pages="0~2" ...>
    <InsertSheet SheetType="FillSheet" SheetUsage="FillForceBack" SheetFormat="Blank" .../>
  </RunList>
  <RunList Run="1" Pages="3~5" .../>
    <InsertSheet SheetType="FillSheet" SheetUsage="FillForceFront" SheetFormat="Blank" .../>
  </RunList>
  <RunList Run="1" Pages="6~-1" .../>
    <InsertSheet SheetType="FillSheet" SheetUsage="FillForceFront" SheetFormat="Blank" .../>
  </RunList>
</RunList>
    
```

The result will be as follows:

x	y	Result
0	2	A fill page will be inserted on the back side of page 2, if page 2 is on the front side.
3	5	A fill page will be included on the back side of page 5, if page 5 is on the front side.
6	-1	Last page range of the document

3.2.19 Hold Job

Hold the job on the spooled queue.

Partition Keys
None

Elements/Resources Used
JDF (Combined Digital Printing Node)

Processes
None

Syntactic Fragment
<JDF ID=... Type="Combined" Types=... Status="Ready" **Activation="held status of job"** ...>

Allowed Values
Activation
MUST be set to one of the following values:
Held Job is held and cannot be processed.
Active Job is released and can be processed.

3.2.20 ICS Versions

The versions of the Interoperability and Conformance Specifications that were used to generate the job ticket.

Partition Keys

None

Elements/Resources Used

JDF (Combined Digital Printing Node)

Processes

None

Syntactic Fragment

```
<JDF ID=... Type="Combined" Types=... Status="Ready" ICSVersions="ICS versions" ...>
```

Allowed Values

ICSVersions

MUST be NMTOKENS of the form <ICSName>_L<ICSLevel>-<ICSVersion>. To include the Integrated Digital Printing ICS, the following MUST be specified:

DP_L1-1.0

3.2.21 Image Shift Back Side

Offset the logical page origin as specified, in micrometers, to the right or left and/or above or below the physical page on the back of the sheet.

Partition Keys

ImageShift - None

LayoutPreparationParams - See Table 65 Partitioning Resources other than RunList for the valid partition keys.

Elements/Resources Used

ImageShift

LayoutPreparationParams

Processes

LayoutPreparation

Syntactic Fragment

```
<LayoutPreparationParams ID="Reference ID" Class="Parameter" Status="Available" >
```

```
  <ImageShift ShiftBack="x and y offset amount" />
```

```
</LayoutPreparationParams>
```

Allowed Values

ID

String that uniquely identifies the LayoutPreparationParams.

ShiftBack

MUST be an XYPair (doubles), that are the amount to shift the image in the x and y directions.

3.2.22 Image Shift Front Side

Offset the logical page origin as specified, in micrometers, to the right or left and/or above or below the physical page on the front of the sheet.

Partition Keys

ImageShift - None

LayoutPreparationParams - See Table 65 Partitioning Resources other than RunList for the valid partition keys.

Elements/Resources Used

ImageShift

LayoutPreparationParams

Processes

LayoutPreparation

Syntactic Fragment

```
<LayoutPreparationParams ID="Reference ID" Class="Parameter" Status="Available" >
```

```
  <ImageShift ShiftFront="x and y offset amount" />
```

```
</LayoutPreparationParams>
```

Allowed Values

ID

String that uniquely identifies the LayoutPreparationParams.

ShiftFront

MUST be an XYPair (doubles), that are the amount, in micrometers, to shift the image in the x and y directions.

3.2.23 Input Tray Name

Name of the input tray that contains the media to be used.

Partition Keys

DigitalPrintingParams - See Table 65 Partitioning Resources other than RunList for the valid partition keys.

Media - Location

Elements/Resources Used

DigitalPrintingParams

Media

MediaRef

Part

Processes

DigitalPrinting

Syntactic Fragment

```
<Media ID="Media reference ID" Class="Consumable" Status="Available"
```

```
  <Location LocationName="name of input tray" />
```

```
</Media>
```

```
<DigitalPrintingParams ID="DigitalPrintingParams reference ID" Class="Parameter"
```

```
  Status="Available ManualFeed="whether or not media will be manually fed">
```

```
  <MediaRef rRef="Media reference ID" />
```

```
</DigitalPrintingParams>
```

Allowed Values

ID

Strings that uniquely identify the Media and DigitalPrintingParams.

rRef

Strings that reference the Media and DigitalPrintingParams by means of their unique IDs.

Location

If present, MUST contain LocationName.

LocationName

If present, MUST be set to one of the following values:

AnySmallFormat
 AnyLargeFormat
 AutoSelect
 Bottom same as Lower
 BypassTray
 BypassTray-*n* where *n* is an integer
 Continuous
 Disc
 Disc-*n* where *n* is an integer
 Envelope
 Envelope-*n* where *n* is an integer
 Front
 InsertTray
 InsertTray-*n* where *n* is an integer
 LargeCapacity same as Main
 LargeCapacity-*n* where *n* is an integer
 Left
 Middle same as Center
 Rear
 Right
 Roll
 Roll-*n* where *n* is an integer
 Side
 Top same as Upper
 Tray
 Tray-*n* where *n* is an integer, same as Cassette

ManualFeed

If present, MUST be a one of the following values:

false	<i>The media will not be fed manually. This is the default.</i>
true	<i>The media will be fed manually. If LocationName is specified for the input tray name, then the media will be manually fed using the specified input tray name. If LocationName is not specified, then the system specified input tray will be used to manually feed the media.</i>

Examples:

The result of the following two examples is the same, page 0 of the RunList is printed on the media loaded in Tray-2 and the rest of the pages of the RunList are printed on the media loaded in Tray-1. In the first example a single media resource is partitioned by Location and in the second example there are two media resources.

1. In the following example the Media resource is partitioned by Location and the DigitalPrintingParams partition for page 0 contains a MediaRef that contains the Media partition for the Cover media loaded in Tray-2.

```

...
<Media ID="M1" PartIDKeys="Location" >
  <Location LocationName="Tray-1" />
  <Media Location="Cover" >
    <Location LocationName="Tray-2" />
  </Media>
</Media>
<DigitalPrintingParams ID="DPP" PartIDKeys="RunIndex" >
  <MediaRef rRef="M1" />

```

```

    <DigitalPrintingParams RunIndex="0" >
      <MediaRef rRef=M1 >
        <Part Location="Cover" />
      </MediaRef>
    </DigitalPrintingParams>
  </DigitalPrintingParams>
  ...

```

2. In the following example there are two Media resources and the DigitalPrintingParams partition for page 0 contains a MediaRef for the media loaded in Tray-2.

```

  ...
  <Media ID="M1" >
    <Location LocationName="Tray-1" />
  </Media>
  <Media ID="M2" >
    <Location LocationName="Tray-2" />
  </Media>
  <DigitalPrintingParams ID="DPP" PartIDKeys="RunIndex" >
    <MediaRef rRef="M1" />
    <DigitalPrintingParams RunIndex="0" >
      <MediaRef rRef=M2" />
    </DigitalPrintingParams>
  </DigitalPrintingParams>
  ...

```

3.2.24 Insert Sheet

Insert a blank (or preprinted) sheet before and/or after a specified page range. If any type of finishing (hole making, stitching, etc.) is specified for the page range, then the insert sheet will be included with the specified page range.

Partition Keys

FileSpec - None
 InsertSheet - None
 LayoutElement - None
 All ResourceRef - None
 Media - None
 RunList - See Table 64 Partitioning RunList for the valid partition keys.
 Sheet - None

Elements/Resources Used

FileSpec
 InsertSheet
 LayoutElement
 All ResourceRef
 Media
 MediaRef
 RunList
 Sheet

Processes

LayoutPreparation

Syntactic Fragment

Following demonstrates how to place an insert sheet before or after a specific page range of a document:

```

<LayoutElement ID="LayoutElement reference ID" Class="Parameter"
  Status="Available" >
  <FileSpec Url="file name" />
</LayoutElement>
<Media ID="Media 2 reference ID" Class="Consumable" Status="Available" />
<RunList ID="RunList reference ID" Class="Parameter" Status="Available"
  PartIDKeys="Run" >
  <RunList Run="insert sheet Run value"
    Pages="x-y page range before or after insert sheet" >
    <LayoutElementRef rRef="LayoutElement reference ID" />
    <InsertSheet SheetType="InsertSheet"
      SheetUsage="where to insert sheet" IsWaste="false" >
      <RunList PageCopies="number of copies of insert sheet" />
      <Sheet>
        <MediaRef rRef="Media 2 reference ID" />
      </Sheet>
    </InsertSheet>
  </RunList>
  <RunList Run="Run value for remainder of document"
    Pages="z~-1 page range after insert sheet" >
    <LayoutElementRef rRef="LayoutElement reference ID" />
  </RunList>
</RunList>

```

Allowed Values**ID**

Strings that uniquely identify the LayoutElement, Media, and RunList.

rRef

Strings that reference the LayoutElement, Media, and RunList by means of their unique IDs.

Run

Strings that are the references to the Run values for the page range before/after the insert sheet or the page range after the insert sheet. The value can be anything that uniquely identifies this RunList partition.

Pages

MUST be present, where:

x~y Insert before (SheetUsage=Header) or after (SheetUsage=Trailer) the range of pages starting with *x* and ending with *y*. *x* is 0 to indicate the first page of the document. *y* is -1 to indicate the last page of the document.

z~-1 Page range after insert sheet to the end of the document.

PageCopies

If present, MUST be an integer in the range 1 through 999. Default is 1.

SheetType

MUST be set to "InsertSheet"

SheetUsage

MUST be set to one of the following values:

Header	Insert sheet before the specified page(s)
Trailer	Insert sheet after the specified page(s)

IsWaste

MUST be set to false.

3.2.25 Interleave Sheets

Whether to interleave a printed or blank sheet between each sheet of the output.

Partition Keys

None

Elements/Resources Used

InsertSheet
LayoutPreparationParams
Media
MediaRef
Sheet

Processes

LayoutPreparation

Syntactic Fragment

```
<Media ID="Interleave media reference ID" Class="Consumable" Status="Available" />
<LayoutPreparationParams ID="LayoutPreparationParams Reference ID" Class="Parameter"
  Status="Available"
  <InsertSheet SheetType="SeparatorSheet"
    SheetUsage="where to insert interleave sheet"
    SheetFormat="type of sheet to interleave"
    IsWaste="false" >
    <Sheet>
      <MediaRef rRef="Interleave media reference ID" />
    </Sheet>
  </InsertSheet>
</LayoutPreparationParams>
```

Allowed Values

ID

Strings that uniquely identify the Media and LayoutPreparationParams .

rRef

Strings that reference the Media and LayoutPreparationParams by means of their unique IDs.

SheetType

MUST be set to "Separator".

SheetUsage

MUST be set to one of the following values:

Interleaved *Interleave sheet is produced after each sheet.*

InterleavedBefore *Interleave sheet is produced before each sheet.*

SheetFormat

MUST be set to one of the following values:

Duplicate *Print same content as previous sheet onto each interleave sheet.*

Blank *Do not print on the interleave sheet. Sheet may be blank or preprinted.*

IsWaste

MUST be set to "false".

3.2.26 Job Created By

Name or user ID of the person who submitted the job. If present, this information MUST be included in the AuditPool of the Combined Digital Printing Node when the Combined Digital Printing Node is created.

Partition Keys

None

Elements/Resources Used

AuditPool

Created

Processes

None

Syntactic Fragment

```
<AuditPool>
  <Created Author="name or user ID of person who created job"
    TimeStamp="date and time of creation" />
</AuditPool>
```

Allowed Values

Author

If present, MUST be a String . This may contain, for example, the user ID and hostname in the form *userID@hostname*.

TimeStamp

MUST be a date and time in ISO 8601 format. If the date and time is not known then zeros for the date and time values can be provided.

3.2.27 Job Identification

IDs that are used to identify a job.

Partition Keys

None

Elements/Resources Used

JDF (Combined Digital Printing Node)

Processes

None

Syntactic Fragment

```
<JDF ID=... Type="Combined" Types=... Status="Ready" JobID="job identifier"
  JobPartID="" RelatedJobID="" RelatedJobPartID="" SpawnID="" ...>
```

Allowed Values

JobID

If present, MUST be a string that identifies a job.

JobPartID

If present, MUST be a string that identifies a JDF node in a job.

RelatedJobID

If present, MUST be a string that identifies a job that is related to this job.

RelatedJobPartID

If present, MUST be a string that identifies a JDF node in a job that is related to this job.

SpawnID

If present, MUST be a string that identifies the spawned part of a job.

3.2.28 Job Modified By

Name or user ID of the person who modified the job. The hostname may also be specified.

Partition Keys

None

Elements/Resources Used

AuditPool
Modified

Processes

None

Syntactic Fragment

```
<AuditPool>
  <Modified Author="name or user ID of person who modified job"
    TimeStamp="date and time of modification" />
</AuditPool>
```

Allowed Values

Author

If present, MUST be a String . This may contain, for example, the user ID and hostname in the form *userID@hostname*.

TimeStamp

MUST be a date and time in ISO 8601 format. If the date and time is not known then zeros for the date and time values can be provided.

3.2.29 Job Name

Either a user friendly name of the job, such as the customer's name for the job and/or the name of the Combined Digital Printing Node.

The customer's name for the job and the name of the Combined Digital Printing Node may be the same. The Device MUST use the name of the Combined Digital Printing Node if it is provided, otherwise the Device MAY use the customer name of the job.

Partition Keys

None

Elements/Resources Used

JDF (Combined Digital Printing Node)
CustomerInfo

Processes

None

Syntactic Fragment

Customer's name of the job:

```
<CustomerInfo CustomerJobName="job name" />
```

Name of the Combined Digital Printing Node:

```
<JDF ID=... Types="Combined" Types=... Status="Ready" DescriptiveName="description of
the Combined Digital Printing Node" >
```

Allowed Values

CustomerJobName

If present, MUST be a string that is a user friendly name of the job.

DescriptiveName

If present, MUST be a string that is the name of the Combined Digital Printing Node.

3.2.30 Job Priority

Scheduling priority of job.

Partition Keys

None

Elements/Resources Used

NodeInfo

Processes

None

Syntactic Fragment`<NodeInfo JobPriority="priority" />`**Allowed Values**

JobPriority

MUST be an integer in the range of 1 through 100, where 1 is the lowest priority and 100 is the highest priority.

3.2.31 Job Ticket Created By

The name and version of the agent application that created the Combined Digital Printing Node.

Partition Keys

None

Elements/Resources Used

AuditPool
Created

Processes

None

Syntactic Fragment

```
<AuditPool >
  <Created AgentName="name of agent application"
    AgentVersion="version of agent application" />
</AuditPool>
```

Allowed Values

AgentName

If present, MUST be a String that identifies the agent application that created the job ticket. This could be a company and or product name.

AgentVersion

If present, MUST be a String that identifies the version of the agent application that created the job ticket.

3.2.32 Job Ticket Template Comment or Description

Text that describes what the job ticket template will be used for or what function it provides.

Partition Keys

None

Elements/Resources Used

JDF (Combined Digital Printing Node)
Comment

Processes

None

Syntactic Fragment

```

<JDF ID=... Type="Combined" Types=... Status="Ready" >
  <Comment Language="language code or language and country code "
    Name="TemplateDescription"
    > job ticket template comment or description text
  </Comment>

```

Allowed Values

Name

MUST be set to "TemplateDescription".

job ticket template comment or description text

String that contains a comment about or a description of the job ticket template.

Language

If present, MUST be set to contain either a language code in the form "en" or a language and country code in the form "en-US".

3.2.33 Job Ticket Template ID

Unique job ticket template identifier. The intended use is by the application or user that created the job ticket template as a way to uniquely identify a job ticket template.

Partition Keys

None

Elements/Resources Used

JDF (Combined Digital Printing Node)

Processes

None

Syntactic Fragment

```

<JDF ID=... Type="Combined" Types=... Status="Ready"
  TemplateID="job ticket template ID" ...>

```

Allowed Values

TemplateID

MUST be a String . Could be a name or ID.

3.2.34 Job Ticket Template Version

The version of the job ticket template. The intended use is by the application or user that created the job ticket template as a way to identify the job ticket template.

Partition Keys

None

Elements/Resources Used

JDF (Combined Digital Printing Node)

Processes

None

Syntactic Fragment

```
<JDF ID=... Type="Combined" Types=... Status="Ready" TemplateVersion="job ticket template version" ...>
```

Allowed Values

TemplateVersion

MUST be a String that may be, for example, in the form a.b, where a is the major version number and b is the minor version number.

3.2.35 Jog Offset

Jog offset between copies of a component and between components.

Partition Keys

None

Elements/Resources Used

DigitalPrintingParams

Disjuncting

Processes

DigitalPrinting

Syntactic Fragment

```
<DigitalPrintingParams ID="Reference ID" Class="Parameter" Status="Available"
  <Disjuncting OffsetDirection="how to jog offset between copies"
    OffsetAmount="number of components to offset simultaneously" />
</DigitalPrintingParams>
```

Allowed Values

ID

String that uniquely identifies the DigitalPrintingParams.

OffsetDirection

MUST be one of the following values:

Alternate

The position of the first component is opposite to the position of the previous component and subsequent components are each offset to alternating positions. For example, if the last item in the stack was positioned to the right then the subsequent items will be positioned to the left, right, left, right, etc.

Left

Offset consecutive components sideways to the left. Left is with respect to the coordinate system feed direction.

None

Do not offset consecutive components. The position of all components is the same as the position of the previous component. This is the default.

Right

Offset consecutive components sideways to the right.

OffsetAmount

If present, MUST be an Integer that specifies the number of components to offset.

3.2.36 Margins

Specifies the width in points of the non-printable margins measured inward from the edges of the media (before trimming).

Note: Because a specific device NEED NOT support a zero value, i.e. the image data might not be imaged to the edge when a zero value is specified.

Partition Keys

DigitalPrintingParams - See Table 65 Partitioning Resources other than RunList for the valid partition keys.

Elements/Resources Used

DigitalPrintingParams

Processes

DigitalPrinting

Syntactic Fragment

```
<DigitalPrintingParams ID="Reference ID" Class="Parameter" Status="Available"
  NonPrintableMarginBottom ="width of bottom margin"
  NonPrintableMarginLeft ="width of left margin"
  NonPrintableMarginRight ="width of right margin"
  NonPrintableMarginTop ="width of top margin" />
```

Allowed Values

ID

String that uniquely identifies the DigitalPrintingParams.

NonPrintableMarginBottom

If present, MUST be a double that is the width of the bottom margin, in points. Specifying zero indicates that there is to be no bottom margin.

NonPrintableMarginLeft

If present, MUST be a double that is the width of the left margin, in points. Specifying zero indicates that there is to be no left margin.

NonPrintableMarginRight

If present, MUST be a double that is the width of the right margin, in points. Specifying zero indicates that there is to be no right margin.

NonPrintableMarginTop

If present, MUST be a double that is the width of the top margin, in points. Specifying zero indicates that there is to be no top margin.

3.2.37 Media

Name and properties of the media on which to print.

Partition Keys

DigitalPrintingParams - See Table 65 Partitioning Resources other than RunList for the valid partition keys.

Media - Location

Elements/Resources Used

Comment

DigitalPrintingParams

Media

MediaRef

Part

Processes

DigitalPrinting

LayoutPreparation

Syntactic Fragment

To print the entire document using the same Media:

```
<Media ID="Media reference ID" Class="Consumable" Status="Available"
  Amount="amount of media available"
```

```

BackCoatings="coating already applied to back side of media"
Brand="brand name of media"
DescriptiveName="short descriptive name of media"
Dimension="media x and y dimensions"
FrontCoatings="coating already applied to front side of media"
HoleType="number of pre-punched holes"
ImageableSide="side of media that may be marked"
LabColorValue="media color in CIELAB color space"
MediaColorName="name of media color"
MediaColorNameDetails="details of media color name"
MediaType="media type"
MediaTypeDetails="media type details"
MediaSetCount="number of media in each set"
MediaUnit="format of media as it is delivered"
Opacity="opacity of the media"
Preprinted="whether media is preprinted or not"
RecycledPercentage="percentage of recycled material in media"
StockType="stock type of media"
Weight="media weight"
<Comment Language="language code or language and country code "
Name="Description"> text description of media </Comment>
</Media>

```

```

<DigitalPrintingParams ID="DigitalPrintingParams reference ID" Class="Parameter"
  Status="Available" >
  <MediaRef rRef="Media reference ID" />
</DigitalPrintingParams>

```

For example, to print part of the document using one Media and the other part using another Media.

```

<Media ID="Media 1 reference ID" Class="Consumable" Status="Available"
  ... same options as shown above ... />
</Media>
<Media ID="Media 2 reference ID" Class="Consumable" Status="Available"
  ... same options as shown above ... />
</Media>

```

```

<DigitalPrintingParams ID="DigitalPrintingParams reference ID"
  Class="Parameter" Status="Available
  PartIDKeys="DocIndex DocRunIndex" >
  <MediaRef rRef="Media 1 reference ID" />
  <DigitalPrintingParams DocIndex="index of document"
    <DigitalPrintingParams
      DocRunIndex="pages or ranges of pages" >
    <MediaRef rRef="Media 2 reference ID" />
  </DigitalPrintingParams>

```

</DigitalPrintingParams>

</DigitalPrintingParams>

Allowed Values**ID**

Strings that uniquely identify the Media and DigitalPrintingParams.

rRef

Strings that reference the Media and DigitalPrintingParams by means of their unique IDs.

DocIndex

Index of document being referenced.

DocRunIndex

x Single page to print on media. Zero or more page numbers can be specified.

x ~ y Range of pages to print on media. Zero or more page ranges can be specified.

Amount

If present, MUST be a double.

BackCoatings

If present, MUST be set to one of the following values:

None

Coated *A coating of a system specified type.*

Glossy

HighGloss

InkJet *A coating intended for use with inkjet technology.*

Matte

Satin

Semigloss

Brand

If present, MUST be a String that is information about the media, such as the manufacturer, model, part number, and/or type.

Dimension

If present, MUST be set to a XYPair (doubles) for x and y dimensions expressed in points. Required if DimensionName is present.

DescriptiveName

If present, MUST be a string that is a short descriptive name of the media.

FrontCoatings

If present, MUST be set to one of the values listed above in BackCoatings.

HoleType

If present, MUST be set to one of the following values:

None *No pre-punched holes. This is the default.*S-generic *System specified number of pre-punched holes for special use*S1-generic *1 pre-punched hole for special use. For example calendar.*R2-generic *2 pre-punched holes, suitable for ring binding*R3-generic *3 pre-punched holes, suitable for ring binding*R4-generic *4 pre-punched holes, suitable for ring binding*R5-generic *5 pre-punched holes, suitable for ring binding***ImageableSide**

If present, MUST be set to one of the following values:

Back

Both

Front

Neither

LabColorValue

Absolute LabColor of the media in CIELAB color space. If present, MUST be in the form "l a b" where l, a, and b are space delimited doubles.

Language

If present, MUST be set to contain either a language code in the form “en” or a language and country code in the form “en-US”.

MediaColorName

If present, MUST be set to one of the following values:

Black
 Blue
 Brown
 Buff
 Cyan
 Gold
 Goldenrod
 Gray
 Green
 Ivory
 Magenta
 MultiColor
 Mustard
 NoColor
 Orange
 Pink
 Red
 Silver
 Turquoise
 Violet
 White
 Yellow

Any of the above with the prefix “Clear”, “Dark” or “Light”.

MediaColorNameDetails

If present, MUST be a String without spaces. If MediaColorNameDetails is present, MediaColorName must be specified.

MediaType

If present, MUST be set to one of the following values:

Disc
 Other
 Paper
 Transparency

MediaTypeDetails

If present, MUST be set to one of the following values:

CardBoard	<i>Thick stock.</i>
ContinuousLong	<i>Continuously connected sheets connected along the long edge.</i>
ContinuousShort	<i>Continuously connected sheets connected along the short edge.</i>
Envelope	<i>Envelopes that can be used for conventional mailing purposes.</i>
EnvelopePlain	<i>Envelopes that are not preprinted and have no windows.</i>
EnvelopeWindow	<i>Envelopes that have windows for addressing purposes.</i>
FullCutTabs	<i>Media with tabs that run full length of media, where only one tab is visible.</i>
Labels	<i>Label stock, e.g., a sheet of peel-off labels.</i>
Letterhead	<i>Media that has a letterhead.</i>
MultiLayer	<i>Form medium composed of multiple layers which are preattached to one another, e.g., for use with impact printers.</i>

MultiPartForm	Form medium composed of multiple layers not preattached to one another; each sheet may be drawn separately from an input source.
Photographic	Separately cut sheets of an opaque material to produce photographic quality images.
PreCutTabs	Media with tabs that are cut so that more than one tab is visible.
Stationery	Media that is stationery.
TabStock	Media with tabs that are either FullCutTabs or PreCutTabs. Use with MediaSetCount for number of tabs.
Tractor	Tractor fed paper.

ISSUE: How is perforated paper specified?

ISSUE: In SJ, Rainer proposed that a group be assigned the task of deciding valid MediaTypeDetails. Martin suggested looking at papiNet. Rainer briefly looked at the spec during the meeting and didn't see that it would be of any help.

6/3 - This still needs to be looked into.

MediaSetCount

If present, MUST be a integer in the range 1 through 65535.

MediaUnit

If present, MUST be set to one of the following values:

Continuous

Roll

Sheet *This is the default.*

Opacity

If present, MUST be set to one of the following values

Opaque

Transparent

Translucent

PrePrinted

If present, MUST be set to one of the following values:

true *The media is preprinted.*

false *The media is not preprinted. This is the default.*

RecycledPercentage

If present, MUST be set to a double that is a percentage, between 0 and 100, of recycled material that the media contains.

StockType

If present, MUST be set to one of the following values:

Bristol

Bond

Cover

Index

Newsprint

Offset *This includes book stock.*

Tag

Text

text description of media

If present, MUST be a string that contains a description of the media.

Weight

If present, MUST be set to a double that is weight of media in grams per square meter.

Example:

The result of the following two examples is the same. Page 0 of the RunList is printed on Cover stock and the rest of the pages of the RunList are printed on Bond stock. In the first example Media is partitioned by Location and in the second example there are two Media resources.

1. In the following example the Media resource is partitioned by Location and the DigitalPrintingParams partition for page 0 contains a MediaRef that contains the Media partition for Cover stock.

```

...
<Media ID="M1" PartIDKeys="Location" StockType="Bond" >
  <Media Location="Cover" StockType="Cover" />
</Media>
<DigitalPrintingParams ID="DPP" PartIDKeys="RunIndex" >
  <MediaRef rRef="M1" />
  <DigitalPrintingParams RunIndex="0" >
    <MediaRef rRef="M1" >
      <Part Location="Cover" />
    </MediaRef>
  </DigitalPrintingParams>
</DigitalPrintingParams>

```

2. In the following example there are two Media resources and the DigitalPrintingParams partition for page 0 contains a MediaRef for the Cover stock.

```

...
<Media ID="M1" StockType="Bond" />
<Media ID="M2" PartIDKeys="Location" StockType="Cover" />
<DigitalPrintingParams ID="DPP" PartIDKeys="RunIndex" >
  <MediaRef rRef="M1" />
  <DigitalPrintingParams RunIndex="0" >
    <MediaRef rRef="M2" />
  </DigitalPrintingParams>
</DigitalPrintingParams>

```

3.2.38 Message to Operator

Message to the operator that contains information regarding the processing of the job. Note: The natural language is not localized by any recipient, since this message is generated by a human.

Partition Keys

None

Elements/Resources Used

JDF (Combined Digital Printing Node)

Comment

Processes

None

Syntactic Fragment

```

<JDF ID=... Type="Combined" Types=... Status="Ready"
  <Comment Language="language code or language and country code "
    Name="Instruction"> message to the operator </Comment>
</JDF>

```

Allowed Values

Name

Always set to Instruction.

message to the operator

MUST be a String that contains a message or instructions for the operator.

Language

If present, MUST be set to contain either a language code in the form "en" or a language and country code in the form "en-US".

3.2.39 MIS Support

Used when the Device is fed by an MIS.

Partition Keys

None

Elements/Resources Used

Component
JDF (Combined Digital Printing Node)
Media

Processes

None

Syntactic Fragment

```
<JDF ID=... Type="Combined" Types=... Status="Ready"
  ProjectID="project identifier" ... >
  ...
  <Component ID="Reference ID" Class="Quantity" ComponentType="FinalProduct"
    Status="Available" ProductID="ID of Component resource defined in MIS" >
  <Media ID="Reference ID" Class="Consumable"
    ProductID="ID of Media resource defined in MIS" >
  ...
</JDF>
```

Allowed Values

ID
String that uniquely identifies the JDF Node, Component, and Media resources.

ProductID
If present, MUST be a string that identifies the Component or Media resource in the MIS.

ProjectID
If present. MUST be a string that identifies the project that this JDF belongs to. Used by the MIS to group a set of JDF jobs.

3.2.40 Named Features

The name of features that are an implementation set of parameters for setting up a Device that the Device must apply to the JDF ticket.

Partition Keys

None

Elements/Resources Used

JDF (Combined Digital Printing Node)

Processes

None

Syntactic Fragment

```
<JDF ID=... Type="Combined" Types=... Status="Ready"
  NamedFeatures="features that Device is to apply" ... >
```

Allowed Values

NamedFeatures
MUST be strings that are an ordered list of name value pairs with an even number of entries.

3.2.41 Notification

Specifies who should be notified when certain events pertaining to the job occur.

Partition Keys

None

Elements/Resources Used

ComChannel
CustomerInfo
CustomerMessage

Processes

None

Syntactic Fragment

```
<CustomerInfo>
  <CustomerMessage Language="language code or language and country code"
    MessageEvents = "set of events that trigger the message" ShowList="UserText"
    UserText="text to accompany notification" >
    <ComChannel>
      ChannelType="how to deliver notification"
      ChannelTypeDetails="details of how to deliver notification"
      Locator="where to deliver notification"
    </ComChannel>
  </CustomerMessage>
</CustomerInfo>
```

Allowed Values.

ChannelType

MUST be set to one of the following values:

Email	An email address to send the events to.
Fax	A fax number to send the events to.
InstantMessaging	An instant message is sent.
JMF	A JMF messaging channel to send the events to.
Phone	A phone number to send the events to.
PrivateDirectory	An account of a registered customer to send events to.
WWW	A WWW home page to send events to.

ChannelTypeDetails

MUST be set to one of the following values:

Landline	Valid when ChannelType is Phone.
Mobile	Valid when ChannelType is Phone.
Secure	Valid when ChannelType is Phone.
ISDN	Valid when ChannelType is Phone.
Target	Valid when ChannelType is WWW to send events to the URL specified in Locator.

Private directory service vendor name

Instant message service vendor name

ISSUE: Should "Form" be included in the above list?

ComChannel

If not present, events are sent to location as specified by the system.

Locator

String that specifies where or to whom the events are to be send. Some examples are a phone number or URL. If ChannelType is:

- Email
- Fax
- JMF
- Phone
- WWW

Locator MUST use the form:

- Locator="mailto:..." URL [RFC2808].
- Locator="fax:..." URL [RFC2808].
- Locator="http://..." URL [RFC2616].
- Locator="tel:..." URL [RFC2808].
- Locator="http://..." URL [RFC2616].

Language
If present, MUST be set to contain either a language code in the form "en" or a language and country code in the form "en-US".

MessageEvents
MUST be set to one or more of the following values:

- Accepted
- JobCompletedSuccessfully
- JobCompletedWithErrors
- JobCompletedWithWarning
- JobInProgress

ShowList
If present, MUST be set to "UserText".

UserText
If present, MUST be set to the text that is to be included in the notification event.

3.2.42 Number of Copies

Number of copies of the job to print.

Partition Keys
None

Elements/Resources Used
ComponentLink

Processes
DigitalPrinting

Syntactic Fragment
<ComponentLink rRef="ID of Component resource" Usage="Output" Amount="number of copies"/>

Allowed Values

- rRef
String that references the Component resource being linked.
- Amount
MUST be present.

3.2.43 Number Up

Number of pages to image on a single side of the sheet.

To produce booklets, use the Number Up feature with the Stapling and Stitching feature on page 132 and the Folding feature on page 91 .

Partition Keys

LayoutPreparationParams - See Table 65 Partitioning Resources other than RunList for the valid partition keys.

Elements/Resources Used

LayoutPreparationParams
FitPolicy
PageCell

Processes

LayoutPreparation

Syntactic Fragment

If the dimensions of the Media are such that the pages will optimally fit on the media sheet:

```
<LayoutPreparationParams ID="Reference ID" Class="Parameter" Status="Available"
  NumberUp="number of pages along x axis and y axis" />
```

If the dimensions of the Media are such that the pages must be rotated to optimally fit on the sheet surface:

```
<LayoutPreparationParams ID="Reference ID" Class="Parameter" Status="Available"
  NumberUp="number of pages along x axis and y axis"
  PresentationDirection="order to distribute pages" >
  <PageCell Rotate="degrees of rotation" />
  <FitPolicy SizePolicy="what to do if content doesn't fit" />
</PageCell>
</LayoutPreparationParams>
```

2/18 - Decided during DP WG meeting to include two cases. One where the media is landscape (11x8.5) so no rotation is necessary and another where the media is portrait (11x8.5) so the page cells must be rotated.

Allowed Values

ID

String that uniquely identifies the LayoutPreparationParams.

NumberUp

MUST be set as follows:

x y Place the pages in *x* columns and *y* rows on the sheet, where *x* and *y* are integers.

Rotate

MUST be set to one of the following values:

Rotate0 This is the default.
Rotate90 Rotate 90 degrees counter-clockwise.
Rotate180
Rotate270 Rotate 90 degrees clockwise.

PresentationDirection

MUST be set to one of the following values:

FoldCatalog Pages are imaged so that the result is compatible with a finished product produced from the folding catalog as specified in FoldCatalog.

- XYZ** Permutations of the letters XYZ and xyz so that exactly one of upper or lower case of x y and z define the order in which content pages are flowed along each axis with respect to the coordinate system of the front side of the sheet.
- X - Specifies flowing left to right across a sheet surface.
 - x - Specifies flowing right to left across a sheet surface.
 - Y - Specifies flowing bottom to top vertically across a sheet surface.
 - y - Specifies flowing top to bottom vertically across a sheet surface.
 - Z - Specifies flowing bottom of stack to top of stack through the stack.
 - z - Specifies flowing top of stack to bottom of stack through the stack.

SizePolicy

If present, MUST be set to one of the following values:

- Abort** *Emit an error and abort printing.*
- ClipToMaxPage** *The page contents should be clipped to the size of the container. The printed area is either centered in the source image.*
- FitToPage** *The page contents should be scaled up or down to fit the media. The aspect ratio is maintained.*
- ReduceToFit** *The page contents should be scaled down but not scaled up to fit the media. The aspect ratio is maintained.*
- Tile** *The page contents should be split into several tiles, each printed on its own surface.*

Examples:

To print 2 columns by 1 row on Media having the dimension 11 x 8.5 inches

```
<LayoutPreparationParams ID="Reference ID" Class="Parameter" Status="Available"
  NumberUp="2 1" />
```

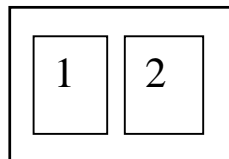

To print 1 column by 2 rows on Media having the dimension 8.5 X 11 inches:

```
<LayoutPreparationParams ID="Reference ID" Class="Parameter" Status="Available"
  NumberUp="1 2"
  PresentationDirection="Yxz >
  <PageCell Rotate="Rotate90" >
    <FitPolicy SizePolicy="ReduceToFit" />
  </PageCell>
</LayoutPreparationParams>
```

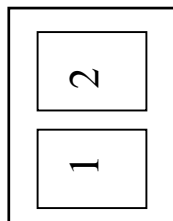

3.2.44 Output Bin Name

Name of the output bin to which output will be directed.

Partition Keys

DigitalPrintingParams - See Table 65 Partitioning Resources other than RunList for the valid partition keys.

Elements/Resources Used

DigitalPrintingParams

Processes

DigitalPrinting

Syntactic Fragment

```
<DigitalPrintingParams ID="Reference ID" Class="Parameter" Status="Available"
  OutputBin="output bin name" />
```

Allowed Values

ID

String that uniquely identifies the DigitalPrintingParams.

OutputBin

MUST be set to one of the following values:

AnyLargeFormat

AnySmallFormat

AutoSelect

Booklet

Bottom same as Lower

Continuous

Disc

Disc-*n* where *n* is an integer

Envelope

Envelope-*n* where *n* is an integer

FaceDown

FaceUp

FitMedia

Front

LargeCapacity same as Main

LargeCapacity-*n* where *n* is an integer

Left

Mailbox-*n* where *n* is an integer

Middle

MyMailbox

Rear

Right

Roll

Roll-*n* where *n* is an integer

Side

Stacker-*n* where *n* is an integer

Top same as Upper

Tray

Tray-*n* where *n* is an integer

3.2.45 Page Delivery

How pages are to be delivered to the output bin or stacker. This feature should only be used if the Controller/Agent has knowledge of how the Device normally delivers the pages to the output bin or stacker and wants a different behavior.

Partition Keys

DigitalPrintingParams - See Table 65 Partitioning Resources other than RunList for the valid partition keys.

Elements/Resources Used

DigitalPrintingParams

Processes

DigitalPrinting

Syntactic Fragment

```
<DigitalPrintingParams ID="Reference ID" Class="Parameter" Status="Available"
  PageDelivery="how to deliver pages" />
```

Allowed Values

ID

String that uniquely identifies the DigitalPrintingParams.

PageDelivery

MUST be set to one of the following values:

Fanfold	Alternate face up and face down.
SameOrderFaceUp	Page order as is with the front sides of the media up.
SameOrderFaceDown	Page order as is with the front sides of the media down.
ReverseOrderFaceUp	Page order reversed with the front sides of the media up.
ReverseOrderFaceDown	Page order reversed with the front sides of the media down.

3.2.46 Page Distribution

How pages are to be distributed onto a multi-up grid of finished page cells. To be used with the Number Up and Presentation Direction features.

Partition Keys

LayoutPreparationParams - See Table 65 Partitioning Resources other than RunList for the valid partition keys.

Elements/Resources Used

LayoutPreparationParams

Processes

LayoutPreparation

Syntactic Fragment

```
<LayoutPreparationParams ID="Reference ID" Class="Parameter" Status="Available"
  PageDistributionScheme="how to distribute the pages" />
```

Allowed Values

ID

String that uniquely identifies the LayoutPreparationParams.

PageDistributionScheme

MUST be set to one of the following values:

Saddle	Distribute pages onto a sequence of one or more imposition layouts in proper order for saddle stitch binding
Perfect	Distribute pages onto a sequence of one or more signatures in proper order for perfect binding
Sequential	The pages are distributed onto the multi-up layout according to the value of the PresentationDirection attribute. This is the default.

3.2.47 Page Order

How the pages in the RunList are ordered.

Partition Keys

LayoutPreparationParams - See Table 65 Partitioning Resources other than RunList for the valid partition keys.

Elements/Resources Used

LayoutPreparationParams

Processes

LayoutPreparation

Syntactic Fragment

```
<LayoutPreparationParams ID="Reference ID" Class="Parameter" Status="Available"
  PageOrder="order of pages" />
```

Allowed Values

ID

String that uniquely identifies the LayoutPreparationParams.

PageOrder

MUST be set to one of the following values:

Booklet

Pages are in booklet order.

Reader

Pages are in reader order. This is the default.

3.2.48 Presentation Direction

Indicates the order in which content pages will be distributed into the page cells. To be used with the Number Up and Page Distribution features.

Partition Keys

LayoutPreparationParams - See Table 65 Partitioning Resources other than RunList for the valid partition keys.

Elements/Resources Used

LayoutPreparationParams

Processes

LayoutPreparation

Syntactic Fragment

```
<LayoutPreparationParams ID="Reference ID" Class="Parameter" Status="Available"
  PresentationDirection="order to distribute pages" />
```

Allowed Values

ID

String that uniquely identifies the <code>LayoutPreparationParams</code> .	
<code>PresentationDirection</code>	<code>MUST</code> be set to one of the following values:
<code>FoldCatalog</code>	<i>Pages are imaged so that the result is compatible with a finished product produced from the folding catalog as specified in <code>FoldCatalog</code>.</i>
<code>XYZ</code>	Permutations of the letters XYZ and xyz so that exactly one of upper or lower case of x y and z define the order in which content pages are flowed along each axis with respect to the coordinate system of the front side of the sheet. <ul style="list-style-type: none"> • X - Specifies flowing left to right across a sheet surface. • x - Specifies flowing right to left across a sheet surface. • Y - Specifies flowing bottom to top vertically across a sheet surface. • y - Specifies flowing top to bottom vertically across a sheet surface. • Z - Specifies flowing bottom of stack to top of stack through the stack. • z - Specifies flowing top of stack to bottom of stack through the stack.

3.2.49 Print Quality

The print quality that the device is to use for the documents in a job.

Partition Keys

`InterpretingParams` - See Table 65 Partitioning Resources other than `RunList` for the valid partition keys.

Elements/Resources Used

`InterpretingParams`

Processes

`Interpreting`

Syntactic Fragment

```
<InterpretingParams ID="Reference ID" Class="Parameter" Status="Available"
  PrintQuality="print quality" />
```

Allowed Values

ID

String that uniquely identifies the `InterpretingParams`.

`PrintQuality`

`MUST` be set to one of the following values:

<code>Draft</code>	<i>Lowest quality available on the device.</i>
<code>High</code>	<i>Highest quality available on the device.</i>
<code>Normal</code>	<i>Default quality provided by the device. This is the default.</i>

3.2.50 Process Color Model

Specifies whether to print in color or black/white.

Note: Conversion from color to black/white is device dependent.

Partition Keys

ColorantControl - See Table 65 Partitioning Resources other than RunList for the valid partition keys.

Elements/Resources Used

ColorantControl

Processes

DigitalPrinting

Syntactic Fragment

```
<ColorantControl ID="Reference ID" Class="Parameter" Status="Available"
  ProcessColorModel="process color model" />
```

Allowed Values

ID

String that uniquely identifies the ColorantControl.

ProcessColorModel

MUST be set to one of the following values

DeviceCMYK

DeviceGray

3.2.51 Proof Print

Whether or not to proof print the job and if so who should approve the proof. The device may print other jobs while the proof print job is waiting for approval.

Partition Keys

None

Elements/Resources Used

Address

ApprovalParams

ApprovalPerson

ComChannel

Company

Contact

DigitalPrintingParams

Person

Processes

DigitalPrinting

Syntactic Fragment

```
<DigitalPrintingParams ID="Reference ID" Class="Parameter" Status="Available"
  DirectProofAmount="number of copies to print for the proof" >
  <ApprovalParams ID="Reference ID" Class="Parameter" Status="Available"
    <ApprovalPerson>
      <Contact ContactTypes="Approver"
        <Address City="city" Country="country"
          PostBox="post office box"
          PostalCode="zip or postal code"
          Region="state or province"
          Street="street address"
          ExtendedAddress="additional address info" />
        <ComChannel ChannelType="communication type"
```

```

        ChannelTypeDetails="details of communication type"
        Locator="communication location" />
    <Company OrganizationName="company/organization name" />
    <Person FirstName="first name"
        FamilyName="family/last name" />
    </Contact>
</ApprovalPerson>
</ApprovalParams>
</DigitalPrintingParams>

```

Allowed Values

ID
String that uniquely identifies the RenderingParams, DigitalPrintingParams, or ApprovalParams.

ApprovalPerson
MUST be present; 1 or more occurrences.

DirectProofAmount
If present, MUST be an Integer. Default is 0.

ContactTypes
MUST be set to "Approver".

City
If present, MUST be a String that is the name of the city.

Country
If present, MUST be a String that is the name of the country.

PostBox
If present, MUST be a String that is the post office box (e.g. P.O. Box 101).

PostalCode
If present, MUST be a String that is the zip or postal code.

Region
If present, MUST be a String that is the state or province.

Street
If present, MUST be a String that is the street address.

ExtendedAddress
If present, MUST be a String that is the additional address information (e.g. Suite 245).

ChannelType
If present, MUST be set to one of the following values:

Email	Email address.
Fax	Fax number.
InstantMessaging	An instant message
JMF	A JMF messaging channel
Phone	Telephone number.
PrivateDirectory	Account of a registered customer of a certain service
WWW	WWW home page or form.

ChannelTypeDetails
If present, MUST be set to one of the following values:

Landline	Valid when ChannelType is Phone.
Mobile	Valid when ChannelType is Phone.
Secure	Valid when ChannelType is Phone.
ISDN	Valid when ChannelType is Phone.
Target	Valid when ChannelType is WWW to send events to the URL specified in Locator.
	Private directory service vendor name
	Instant message service vendor name

Locator
ISSUE: Should the "Form" value be included in the above list?

If present, MUST be a String that is the details about how to communicate (e.g. phone number, fax number, email address, URL).

If ChannelType is:	Locator MUST use the form:
Email	Locator="mailto:..." URL [RFC2808].
Fax	Locator="fax:..." URL [RFC2808].
JMF	Locator="http://..." URL [RFC2616].
Phone	Locator="tel:..." URL [RFC2808].
WWW	Locator="http://..." URL [RFC2616].

OrganizationName

If present, MUST be a String that is the name of the company or organization.

FirstName

If present, MUST be a String that is the first or given name of the contact.

FamilyName

If present, MUST be a String that is the family or last name of the contact.

3.2.52 Punching and Hole Making

How many holes to punch and where to punch the holes in the output.

Partition Keys

Component - None

ComponentLink - None

HoleMakingParams - See Table 65 Partitioning Resources other than RunList for the valid partition keys.

Elements/Resources Used

Component

ComponentLink

HoleMakingParams

Processes

HoleMaking

Syntactic Fragment

```
<ComponentLink rRef="ID of Component resource "
  Usage="Intermediate" CombinedProcessIndex="index into Types for HoleMaking"
  Orientation="which edge to punch" />
```

...

```
<Component ID="Reference ID" ComponentType="PartialProduct" Status="Available" />
```

```
<HoleMakingParams ID="Reference ID" Class="Parameter" Status="Available"
```

```
  NoOp="whether or not to punch holes"
```

```
  HoleType="number, size, spacing, and style name of holes to punch" />
```

Allowed Values

ID

String that uniquely identifies the HoleMakingParams.

NoOp

If present, MUST be set to one of the following values:

true To turn hole making off. All other HoleMakingParams attributes are ignored.

false To use other HoleMakingParams attributes to specify hole making. This is the default.

Component

MUST be present if Orientation is specified.

ComponentLink

MUST be present if Orientation is specified.

ComponentType	MUST be set to "PartialProduct".
CombinedProcessIndex	MUST be an Integer.
Orientation	MUST be present if punching on other than the y-axis is desired. If present, MUST be set to one of the following values:
Rotate0	<i>Don't rotate the sheet. Punching is to occur on the edge that is along the y-axis (left edge) of the sheet.</i>
Rotate90	<i>Rotate the sheet 90 degrees counter-clockwise. Punching is to occur on the edge that is opposite the x-axis (top edge) of the pre-rotated sheet.</i>
Rotate180	<i>Rotate the sheet 180 degrees. Punching is to occur on the edge that is opposite of the y-axis (right edge) of the pre-rotated sheet.</i>
Rotate270	<i>Rotate the sheet 270 degrees. Punching is to occur on the edge that is along the x-axis (bottom edge) of the pre-rotated sheet.</i>
Flip0	<i>Do not rotate the sheet, flip the sheet around the x-axis. Punching is to occur on the edge that is along the y-axis (left edge) of the pre-flipped sheet.</i>
Flip90	<i>Rotate the sheet 90 degrees counter-clockwise and flip around the x-axis. Punching is to occur on the edge that is opposite the x-axis (top edge) of the pre-rotated/flipped sheet.</i>
Flip180	<i>Rotate the sheet 180 degrees and flip around the x-axis. Punching is to occur on the edge that is opposite of the y-axis (right edge) of the pre-rotated/flipped sheet.</i>
Flip270	<i>Rotate the sheet 270 degrees counter-clockwise and flip around the x-axis. Punching is to occur on the edge that is along the x-axis (bottom edge) of the pre-rotated/flipped sheet.</i>
Usage	MUST be set to "Intermediate".
HoleType	SHOULD be set to one of the following values:
S-generic	<i>Punch the system specified number of holes for special use.</i>
S1-generic	<i>Punch 1 hole for special use. For example calendar.</i>
R2-generic	<i>Punch 2 holes suitable for ring binding</i>
R3-generic	<i>Punch 3 holes suitable for ring binding</i>
R4-generic	<i>Punch 4 holes suitable for ring binding</i>
R5-generic	<i>Punch 5 holes suitable for ring binding</i>

3.2.53 Range of Pages to Include

Range of pages from the LayoutElement that are to be included in the RunList

Partition Keys

LayoutElement - None

All ResourceRef - None

RunList - See Table 64 Partitioning RunList for the valid partition keys.

Elements/Resources Used

LayoutElement

All ResourceRef

RunList**Processes**

LayoutPreparation

Syntactic Fragment

```

<LayoutElement ID="LayoutElement reference ID" Class="Parameter" Status="Available" >
  <FileSpec URL="file name" />
</LayoutElement>
<RunList ID="RunList reference ID" Class="Parameter" Status="Available"
  PartIDKeys="Run" >
  <RunList Run="Run value"
    Pages="pages or ranges of pages to include"
    NPage="number of pages to include">
    <LayoutElementRef="LayoutElement reference ID" />
  </RunList>
</RunList>

```

Allowed Values**ID**

Strings that uniquely identify the LayoutElement and RunList.

rRef

Strings that reference the LayoutElement and RunList by means of their unique IDs.

Run

String that uniquely identifies a specific partition of the RunList.

NPage

If present, MUST be the number of pages defined by the RunList.

Pages

Page numbering is zero-based: "0". Negative values select pages from the end of the LayoutElement where "-1" is the last page in the LayoutElement, -2 the second to last, etc. If not present, the default is as if Pages is set to "0~-1".

x

Page number from the LayoutElement to include in the RunList. Zero or more page numbers may be specified.

x~y

Range of pages from the LayoutElement to include in the RunList, where x is the first page and y is the last page of the range to include from the LayoutElement. Zero or more page ranges may be specified.

URL

MUST be set to the location of the file in the form as specified in [URL-AppNote].

Examples:

1. The result of the following is that pages 0, 3, 5, 8 through 12, and 20 through the end of file1.pdf are included in the RunList:

```

<RunList ID="RL" Class="Parameter" Status="Available" PartIDKeys="Run" >
  <LayoutElement ID="LE" Class="Parameter" Status="Available" >
    <FileSpec URL="file1.pdf" />
  </LayoutElement>
  <RunList Run="1" Pages="0 3 5" />
  <RunList Run="2" Pages="8~12" />
  <RunList Run="3" Pages="20~-1" />
</RunList>

```

2. The result of the following is that all pages of file2.pdf and just the last two pages of file3.pdf are included in the RunList:

```

<RunList ID="RL" Class="Parameter" Status="Available" PartIDKeys="Run" >

```

```

    <RunList Run="1" >
      <LayoutElement ID="LE1" Class="Parameter" Status="Available >
        <FileSpec URL="file2.pdf" />
      </LayoutElement>
    </RunList>
  <RunList Run="2" Pages="-2~-1" >
    <LayoutElement ID="LE2" Class="Parameter" Status="Available >
      <FileSpec URL="file3.pdf" />
    </LayoutElement>
  </RunList>
</RunList>

```

3.2.54 Range of Pages to Output

Range of pages in the job, document, set, or bundle item to output. The value specified must be a subset of Range of Pages to Include on page 125. If not specified, it defaults to Range of Pages to Include.

If two-sided printing is specified, then the pages selected by partitioning the RunListLink may not appear on the same side of the sheet that they would have appeared on if all of the pages in the RunList were output. The pages will be imaged consecutively starting on the front side of the first sheet, followed by the back side of the first sheet, followed by the front side of the second sheet, etc.

Partition Keys

Part - None

RunListLink - See Table 65 Partitioning Resources other than RunList for the valid partition keys.

Elements/Resources Used

Part

RunListLink

Processes

LayoutPreparation

Syntactic Fragment

The following syntactic fragment must be used when specific pages of the RunList are to be output:

```

<RunList ID="RunList reference ID" Class="Parameter" Status="Available"
  PartIDKeys="Run" >
  <RunList Run="Run value" >
    <LayoutElement ID="LayoutElement reference ID" Class="Parameter"
      Status="Available >
      <FileSpec URL="file name" />
    </LayoutElement>
  </RunList>
</RunList>
...
<RunListLink rRef="ID of RunList resource being referenced" Usage="Input">
  <Part RunIndex="pages or ranges of pages of job to output" />
</RunListLink>

```

The following syntactic fragment must be used when specific documents, sets, or bundle items are to be output:

```

<RunList ID="RunList reference ID" Class="Parameter" Status="Available"
  PartIDKeys="Run" >
  <RunList Run="Run value" EndOfDocument | EndOfSet | EndOfBundleItem="true">
    <LayoutElement ID="LayoutElement reference ID" Class="Parameter"
      Status="Available >
      <FileSpec URL="file 1 name" />
    </LayoutElement>

```

```

</RunList>
<RunList Run="Run value" EndOfDocument | EndOfSet | EndOfBundleItem = "true">
  <LayoutElement ID="LayoutElement reference ID" Class="Parameter"
    Status="Available" >
    <FileSpec URL="file 2 name" />
  </LayoutElement>
</RunList>
</RunList>
...
<RunListLink rRef="ID of RunList resource being referenced" Usage="Input" >
  <Part DocIndex | SetIndex | BundleItemIndex=
    "indices of documents, sets, or bundle items" />
</RunListLink>

```

The following syntactic fragment must be used when specific pages of specific documents or sets are to be output:

```

<RunList ID="RunList reference ID" Class="Parameter" Status="Available"
  PartIDKeys="Run" >
  <RunList Run="Run value" EndOfDocument | EndOfSet="true">
    <LayoutElement ID="LayoutElement reference ID" Class="Parameter"
      Status="Available" >
      <FileSpec URL="file 1 name" />
    </LayoutElement>
  </RunList>
  <RunList Run="Run value" EndOfDocument | EndOfSet="true">
    <LayoutElement ID="LayoutElement reference ID" Class="Parameter"
      Status="Available" >
      <FileSpec URL="file 2 name" />
    </LayoutElement>
  </RunList>
</RunList>
...
<RunListLink rRef="ID of RunList resource being referenced" Usage="Input" >
  <Part DocIndex | SetIndex="index of document or set"
    DocRunIndex | SetRunIndex=
      "pages or ranges of pages of document or set to output" />
  ... Partitions for additional DocIndex/DocRunIndex may appear here
</RunListLink>

```

Allowed Values

ID and rRef

String that uniquely identifies the RunList.

rRef

String that references the RunList by means of its unique ID.

RunIndex, DocRunIndex, or SetRunIndex

Page numbering is zero-based: "0". Negative values select pages from the end of the LayoutElement where "-1" is the last page in the LayoutElement, -2 the second to last, etc. If not present, the default is as if Pages is set to "0~-1".

x

Page number from the LayoutElement to include in the RunList. Zero or more page numbers may be specified.

x~y

Range of pages from the LayoutElement to include in the RunList, where x is the first page and y is the last page of the range to include from the LayoutElement. Zero or more page ranges may be specified.

DocIndex, SetIndex, or BundleItemIndex

MUST be set to an IntegerRangeList that represents the indices of the documents, sets, or bundle items in the job.

3.2.55 Rotate Sheet Content

Degrees to rotate the content on the surface of the sheet with respect to the media coordinate system.

This feature only covers the case where the specified rotation is applied to the entire sheet.

Partition Keys

LayoutPreparationParams - See Table 65 Partitioning Resources other than RunList for the valid partition keys.

Elements/Resources Used

LayoutPreparationParams

Processes

LayoutPreparation

Syntactic Fragment

```
<LayoutPreparationParams ID="Reference ID" Class="Parameter" Status="Available"
  Rotate="degrees of rotation" />
```

Allowed Values

ID

String that uniquely identifies the LayoutPreparationParams.

Rotate

MUST be set to one of the following values:

Rotate0 *This is the default.*

Rotate90 *Rotate 90 degrees counter-clockwise.*

Rotate180

Rotate270 *Rotate 90 degrees clockwise.*

3.2.56 Screening

Vendor specific screening family name or screening type to use.

Partition Keys

ScreeningParams - See Table 65 Partitioning Resources other than RunList for the valid partition keys.

ScreenSelector - None

Elements/Resources Used

ScreeningParams

ScreenSelector

Processes

Screening

Syntactic Fragment

```
<ScreeningParams ID="Reference ID" Class="Parameter" Status="Available" >
  <ScreenSelector ScreeningFamily="vendor-specific screening family name"
    ScreeningType="general type of screening"/>
</ScreeningParams>
```

Allowed Values

ID

String that uniquely identifies the ScreeningParams.

ScreeningFamily

If present, MUST be a string that identifies the screening family name.

ScreeningType

If present, MUST be set to one of the following values:

Adaptive
 AM
 ErrorDiffusion
 FM
 HybridAM-FM
 HybridAMline-dot

3.2.57 Settings Policy

Indicates what happens when unsupported attributes, attribute values, or subelements of a resource or element are present.

Note: SettingsPolicy MUST be specified on a subelement if the SettingsPolicy for the attributes of the subelement is to be affected.

Partition Keys

None

Elements/Resources Used

All

Processes

None

Syntactic Fragment

To specify the same Settings Policy for all resources and elements:

```
<JDF ... SettingsPolicy="what to do" />
```

To specify a Settings Policy for a specific resource:

```
<Resource ... SettingsPolicy="what to do"
  BestEffortExceptions="attributes that are BestEffort"
  MustHonorExceptions="attributes that are MustHonor"
  OperatorInterventionExceptions="attributes that are OperatorIntervention"
/>
```

To specify a Settings Policy for a specific element that is not derived from Abstract Resource and is not the Combined Digital Printing Node:

```
<Element ...
  BestEffortExceptions="attributes that are BestEffort"
  MustHonorExceptions="attributes that are MustHonor"
  OperatorInterventionExceptions="attributes that are OperatorIntervention"
/>
```

Allowed Values

SettingsPolicy

MUST be set to one of the following values:

BestEffort

Substitute or ignore unsupported attributes, attribute values, default attribute values, or elements and continue processing the job.

MustHonor

Reject the job when any unsupported attributes, attribute values, or elements are present.

OperatorIntervention

Pause job and query the operator when any unsupported attributes, attribute values, or elements are present. If a device has no operator intervention capabilities, OperatorIntervention is treated as MustHonor.

Note: If not specified, SettingsPolicy is inherited from the parent element, and if not specified in the parent element or further superior element, the default value defaults to “BestEffort”.

BestEffortExceptions

If present, MUST be set to the names of the attributes for this element that are to treated as BestEffort when SettingsPolicy is set to MustHonor or OperatorIntervention.

MustHonorExceptions

If present, MUST be set to the names of the attributes for this element that are to treated as MustHonor when SettingsPolicy is set to BestEffort or OperatorIntervention.

OperatorInterventionExceptions

If present, MUST be set to the names of the attributes for this element that are to treated as OperatorIntervention when SettingsPolicy is set to BestEffort or MustHonor.

3.2.58 Sides

Whether to print on one or two sides the sheet.

Partition Keys

LayoutPreparationParams - See Table 65 Partitioning Resources other than RunList for the valid partition keys.

Elements/Resources Used

LayoutPreparationParams

Processes

LayoutPreparation

Syntactic Fragment

To print the entire document the same:

```
<LayoutPreparationParams ID="Reference ID" Class="Parameter"
    Status="Available" Sides="sides to print on" />
```

Allowed Values

ID

String that uniquely identifies the LayoutPreparationParams.

Sides

MUST be set to one of the following values:

OneSidedBackFlipX

Page content is imaged on the back side of media so that the corresponding page cells back up to a blank front cell when flipping around the X axis. Equivalent to “WorkAndTumble” with a blank front side.

OneSidedBackFlipY

Page content is imaged on the back side of media so that the corresponding page cells back up to a blank front cell when flipping around the Y axis. Equivalent to “WorkAndTurn” with a blank front side.

OneSidedFront

Page content is imaged on the front side of media.

TwoSidedFlipX

Page content is imaged on both the front and back sides of media sheets so that the corresponding page cells back up to each other when flipping around the X axis. Equivalent to “WorkAndTumble”.

TwoSidedFlipY

Page content is imaged on both the front and back sides of media sheets so that the corresponding page cells back up to each other when flipping around the Y axis. Equivalent to “WorkAndTurn”.

3.2.59 Spot Color

Separation to render spot color.

Partition Keys

ColorantControl - See Table 65 Partitioning Resources other than RunList for the valid partition keys.

ColorantParams - None

SeparationSpec - None

Elements/Resources Used

ColorantControl

ColorantParams

SeparationSpec

Processes

Interpreting

Syntactic Fragment

```
<ColorantControl ID="Reference ID" Class="Parameter" Status="Available" >
  <ColorantParams>
    <SeparationSpec Name="separation name" />
  </ColorantParams>
</ColorantControl>
```

Allowed Values

ID

String that uniquely identifies the ColorantControl.

Name

MUST be a String that is the name of the separation spec.

3.2.60 Stapling and Stitching

How specific pages, documents, or job should be stapled/stitched together.

Partition Keys

Component - None

ComponentLink - None

StitchingParams - See Table 65 Partitioning Resources other than RunList for the valid partition keys.

Elements/Resources Used

Component

ComponentLink

StitchingParams

Processes

Stitching

Syntactic Fragment

```
<ComponentLink rRef="ID of Component resource "
  Usage="Intermediate" CombinedProcessIndex="index into Types for Stitching"
  Orientation="which edge to stitch" />
...
<Component ID="Reference ID" ComponentType="PartialProduct" Status="Available" />
<StitchingParams ID="Reference ID" Class="Parameter" Status="Available"
  NoOp="whether or not to stitch"
  Angle="angle of stitch"
  NumberOfStitches="number of stitches"
```

StitchType=*"position of stitches"* />

Allowed Values

ID

String that uniquely identifies the StitchingParams.

NoOp

If present, MUST be set to one of the following values:

- true To turn stitching off. All other StitchingParams attributes are ignored.
- false To use other StitchingParams attributes to specify stitching. This is the default.

Component

MUST be present if Orientation is specified

ComponentLink

MUST be present if Orientation is specified.

ComponentType

MUST be set to "PartialProduct".

CombinedProcessIndex

MUST be an Integer.

Orientation

MUST be present if stitching on other than the y-axis is desired. If present, MUST be set to one of the following values:

- Rotate0 *Don't rotate the sheet. Stitching is to occur on the edge that is along the y-axis (left edge) of the sheet.*
- Rotate90 *Rotate the sheet 90 degrees counter-clockwise. Stitching is to occur on the edge that is opposite the x-axis (top edge) of the pre-rotated sheet.*
- Rotate180 *Rotate the sheet 180 degrees. Stitching is to occur on the edge that is opposite of the y-axis (right edge) of the pre-rotated sheet*
- Rotate270 *Rotate the sheet 270 degrees. Stitching is to occur on the edge that is along the x-axis (bottom edge) of the pre-rotated sheet.*
- Flip0 *Do not rotate the sheet, flip the sheet around the x-axis. Stitching is to occur on the edge that is along the y-axis (left edge) of the pre-flipped sheet.*
- Flip90 *Rotate the sheet 90 degrees counter-clockwise and flip around the x-axis. Stitching is to occur on the edge that is opposite the x-axis (top edge) of the pre-rotated/flipped sheet.*
- Flip180 *Rotate the sheet 180 degrees and flip around the x-axis. Stitching is to occur on the edge that is opposite of the y-axis (right edge) of the pre-rotated/flipped sheet.*
- Flip270 *Rotate the sheet 270 degrees counter-clockwise and flip around the x-axis. Stitching is to occur on the edge that is along the x-axis (bottom edge) of the pre-rotated/flipped sheet.*

Usage

MUST be set to "Intermediate".

Angle

If present, MUST be an integer that is the angle, in degrees, of each stitch; Increasing in the counterclockwise direction. Valid values are 0 through 359, where 0 is horizontal or parallel to the x axis. The default is system specified. If StitchType is Saddle, Angle is ignored.

NumberOfStitches

If present, MUST be an integer in the range of 1 through 255. If NumberOfStitches is not present or is set to -1, the system specifies the number of stitches. The default is -1.

StitchType

If present, MUST be set to one of the following values:

Corner

Stitch in the corner that is at the clockwise end of the y-axis after Orientation is applied.

Saddle

Stitch on the middle fold which is on the saddle parallel to the y-axis after Orientation is applied.

Side

Stitch along the y-axis after Orientation is applied. If NumberOfStitches is 1, then the stitch is placed parallel to the y-axis after Orientation is applied and in the corner that is at the clockwise end of the y-axis after Orientation is applied.

3.2.61 Start, Separator/Slip, End Sheets

Whether start, separator/slip, and/or end sheets are to be included with the job. If any type of finishing (hole making, stitching, etc.) is specified for any part of the job, the start, separator/slip, and end sheets will not be included in the finishing.

Partition Keys

None

Elements/Resources Used

InsertSheet

JobField

LayoutPreparationParams

MarkObject

Media

MediaRef

Sheet

Surface

Processes

LayoutPreparation

Syntactic Fragment

```

<Media ID="Media reference ID" Class="Consumable" Status="Available" ... />
<LayoutPreparationParams ID="Reference ID" Class="Parameter" Status="Available" >
  <InsertSheet SheetType="type of insert sheet to include"
    IsWaste="whether or not to discard separator sheets"
    SheetUsage="where to include separator sheet"
    SheetFormat="what it to appear on separator sheet" >
    IncludeInBundleItem="which bundle item to include this insert sheet in"
  <Sheet>
    <MediaRef rRef="Media reference ID" />
    <Surface Side="side to print UserText on">
      <MarkObject>
        <JobField
          ShowList="type of text to place on sheet"
          UserText="text to place on sheet"
        </JobField>
      </MarkObject>
    </Surface>
  </Sheet>
</InsertSheet>
</LayoutPreparationParams>

```

Allowed Values

ID	String that uniquely identifies the LayoutPreparationParams.
IncludeInBundleItem	If present, MUST be set to one of the following values: <ul style="list-style-type: none"> After <i>This InsertSheet is to be included in the BundleItem that occurs after this InsertSheet. “After” is equivalent to “None” if no BundleItem is defined after this InsertSheet</i> Before <i>This InsertSheet is to be included in the BundleItem that occurs before this InsertSheet. “Before” is equivalent to “None” if no BundleItem is defined before this InsertSheet</i> New <i>A new BundleItem is created. This InsertSheet will be in the new BundleItem by itself unless another InsertSheet with IncludeInBundleItem = “Before” occurs immediately after this InsertSheet.</i> None <i>This InsertSheet is not included in a BundleItem. This is the default.</i>
IsWaste	If present, MUST be set to one of the following boolean values: <ul style="list-style-type: none"> false <i>Separator sheets are not to be discarded after the completion of the job.</i> true <i>Separator sheets are to be discarded after the completion of the job.</i>
SheetFormat	If present, MUST be set to one of the following values: <ul style="list-style-type: none"> Blank <i>Content of Separator sheet is to be blank.</i> Brief <i>Content of Separator sheet is the brief version.</i> Full <i>Content of Separator sheet is the full version.</i> Standard <i>Content of Separator sheet is the standard.</i>
SheetType	MUST be set to one of the following values: <ul style="list-style-type: none"> JobSheet <i>Include a sheet that delimits the job</i> SeparatorSheet <i>Include a sheet that delimits each copy of each document in the job.</i>
SheetUsage	MUST be set to one of the following values: <ul style="list-style-type: none"> Trailer <i>Include an insert sheet at the end of the job when SheetType=JobSheet or at the end of each copy of each document in the job when SheetType=SeparatorSheet.</i> Slip <i>Include an insert sheet between each copy of each document in the job when SheetType=SeparatorSheet.</i> SlipCopy <i>Include an insert sheet between copies of the job when SheetType=SeparatorSheet.</i> Header <i>Include an insert sheet at the start of the job when SheetType=JobSheet or at the start of each copy of each document in the job when SheetType=SeparatorSheet.</i>
Side	MUST be set to one of the following values: <ul style="list-style-type: none"> Back Front
ShowList	MUST be set to one of the following values: <ul style="list-style-type: none"> JobName JobSubmitterName UserText
Surface	MUST be present if text is to appear on the Separator Sheet.
UserText	MUST be the String that is to appear on the Separator Sheet.

3.2.62 Trapping

Whether trapping is to be performed or not. The type of trapping, raster or vector (see Figure 3-1 Process and Resource Flow on page 19), that is performed depends on where the Trapping process occurs in the Types attribute in the Combined Digital Printing Node. Raster trapping occurs when the RunList is ByteMap elements, otherwise vector trapping occurs.

ISSUE: PODi asked how the Controller/Agent would specify and how the Device would know whether to perform Raster versus Vector Trapping.

Partition Keys

TrappingDetails - See Table 65 Partitioning Resources other than RunList for the valid partition keys.

Elements/Resources Used

TrappingDetails

Processes

Trapping

Syntactic Fragment

```
<TrappingDetails ID="Reference ID" Class="Parameter" Status="Available"
  NoOp="whether or not to perform trapping"/>
```

Allowed Values

ID

String that uniquely identifies the TrappingDetails.

NoOp

If present, MUST be set to one of the following values:

true To turn trapping off. All other TrappingDetails attributes are ignored.

false To use other TrappingDetails attributes to specify trapping. This is the default.

3.2.63 Trimming

Perform a trimming operation on the final product.

Partition Keys

TrimmingParams - See Table 65 Partitioning Resources other than RunList for the valid partition keys.

Elements/Resources Used

TrimmingParams

Processes

Trimming

Syntactic Fragment

```
<TrimmingParams ID="Reference ID" Class="Parameter" Status="Available"
  NoOp="whether or not to trim "/>
```

Allowed Values

ID

String that uniquely identifies the TrimmingParams.

NoOp

If present, MUST be set to one of the following values:

true To turn trimming off. All other TrimmingParams attributes are ignored.

false To use other TrimmingParams attributes to specify trimming.

This is the default.

4 Conformance Requirements for <fill in your ICS>

See [JDF] section 1.4.2.4 Conformance Requirements for Support of Combined Processes. This section specifies the conformance requirements for Controller/Agents and Devices.

4.1 Conformance Requirements for Controller/Agents

[You MUST list the conformance requirements for the Producer of your Interface as one more Conformance Levels, Modules, and/or Profiles.]

A Controller/Agent conforming to this ICS:

1. MUST produce JDF instances that conform to [JDF].
2. MUST meet the conformance requirements for what a Controller produces and consumes according to section 3 of this ICS.
3. MAY produce and consume processes, elements, attributes, and attribute values *not* explicitly specified in section 3 of this ICS as long as the Controller/Agent has a mode of operation that the user can select or configure that always produces and consumes *only* the processes, elements, attributes, and attribute values *explicitly* specified in section 3.

4.2 Conformance Requirements for Devices

A Device conforming to this ICS:

1. MUST consume JDF instances according to [JDF].
2. MUST meet the conformance requirements for what a Device consumes and produces according to section 3 of this ICS.
3. MAY consume and produce processes, elements, attributes, and attribute values *not* explicitly specified in section 3 of this ICS as long as the Device has a mode of operation that the user can select or configure that always consumes and produces *only* the processes, elements, attributes, and attribute values *explicitly* specified in section 3.

5 References

CIP4 documents are available at <http://www.cip4.org>. RFCs are available at: <http://www.rfc-editor.org/rfcsearch.html>. Internet-Drafts are available at: <http://www.ietf.org/ID.html>. IEEE-ISTO PWG standards are located at: <http://www.pwg.org> or more specifically at: <http://www.pwg.org/ipp/index.html>.

5.1 Normative References

[BASE-ICS]

Base Conformance Levels ICS, February 2004.

[JDF]

CIP4 Job Definition Format (JDF), JDF/1.2, February 2004

[RFC2616] *RFC 2616 Hypertext Transfer Protocol — HTTP/1.1*, Date: June 1999, Produced by: Internet Engineering Task Force (IETF), Network Working Group, Available at: All IETF (Internet Engineering Task Force) RFCs (Request for Comments) are available at RFC Database search: <http://www.rfc-editor.org/rfcsearch.html>.

[RFC2808] *RFC 2806, URLs for Telephone Calls*, by A. Vaha-Sipila, Date: April 2000, Produced by: Internet Engineering Task Force (IETF), Network Working Group, Available at: All IETF (Internet Engineering Task Force) RFCs (Request for Comments) are available at RFC Database search: <http://www.rfc-editor.org/rfcsearch.html>.

5.2 Informative References

[DP-AppNote]

Integrated Digital Printing Application Note, version 1.0, work in progress, Available at <http://www.cip4.org>.

[ICS-std]

Hastings, “Standard for Writing a JDF Interoperability Conformance Specification (ICS)”, version 1/0, 30 January 2003. See file: Standard-for-ICS-v1.0.doc, .pdf

[URL-AppNote]

File URL Application Note, Available at www.cip4.org.

6 Contributors

Claudia Alimpich - IBM

Tim Donahue - NexPress Solutions LLC

Tom Hastings - Xerox

Steve Hiebert - Hewlett Packard

Rick Keeney - EFI

Rainer Prosi - Heidelberger Druckmaschinen AG

Stephen Strasen - Xerox

7 Author's Address

Claudia Alimpich

IBM

6300 Diagonal Highway

Boulder, CO 80302

Phone: 1+303-924-4418

e-mail: alimpich@us.ibm.com

Annex A <Changes to Consider for JDF 1.3> (Informative)

Following are items that should be considered for change in JDF 1.3:

1. The Separator Sheet feature uses `LayoutPreparationParams/InsertSheet`, where multiple `InsertSheet` resources can be specified. It makes sense that `DigitalPrintingParams/Disjointing/InsertSheet` should be used instead. `DigitalPrintingParams/Disjointing/@OffsetDirection` is currently used for the Jog Offset feature. There are a couple of alternatives to consider:
 - a. Only 0 or 1 `Disjointing` resources can currently be specified, so the `?` would have to be changed to `*`. Then what would it mean if there are multiple `Disjointing` resources specified where different values for `OffsetDirection` are specified? `OffsetDirection` for each `InsertSheet` can currently be specified. How can offsetting the job versus offsetting the insert sheet be specified? What about offsetting the copies of a job or the sets/documents in a job?
 - b. Only 0 or 1 `Disjointing/InsertSheet` resources can be specified, so the `?` would have to be changed to `*`. What if `OffsetDirection` for the `InsertSheet` needs to be specified?
 - c. Be sure to consider the Interleave Sheets feature and if `Disjointing` should be allowed for this type of `InsertSheet`.
2. `RunTag` can currently be used to reference a label in PPML. Should `SetTag`, `DocTag`, and `PageTag` be added as partition keys so that sets, documents, and pages can all be referenced?
3. Should the Print Quality feature be enhanced to include the functionality provided by the new IPP `print-content-optimize` attribute? This would require that a new attribute be added to JDF.

Annex B <Additions to Consider for Next Release of ICS> (Informative)

Following are items to consider the next release of the ICS:

1. PODi has requested that additional features be added to this ICS in support of color (for example color profile).
2. Add Physical Resource IdentificationField subelement and attributes to suport bar code.

Change Log (Informative)

B.1 Changes to make version 0.01, January 31, 2003

Initial version.

B.2 Changes to make version 0.02, March 2, 2003

1. Changed definitions for Scope, Syntax, Type, and Allowed Values in Section 3 to be in table format. Added Processes to table.
2. Added Processes heading and appropriate process(es) for each function in section 3.
3. Changed Binding function to use SpineTapingParams and CoverApplicationParams instead of BindingParams. Removed ISSUE.
4. Changed Comment/Description of Job function to use Name="Description" instead of "JobDescription" and to not be under RunList. Removed ISSUE.
5. Added Approver as value for ContactTypes in Contact Information function.
6. Removed DescriptionType="FoldProc", From, To, and Travel attributes from Folding function so that the only folding that is possible is by referring to a specific value for FoldCatalog.
7. Renamed Start Page function to Force Page.
8. Added AnySmallFormat, AnyLargeFormat, BypassTray-*n*, Envelope-*n*, InsertTray, InsertTray-*n*, LargeCapacity-*n* as values for the Input Tray Name function's LocationName attribute. Removed ISSUE.
9. Changed Interleave Sheets function's InsertSheet element to reside under LayoutPreparationParams instead of RunList. Removed SheetFormat ISSUE.
10. Changed Job Ticket Comment or Description function to be Job Ticket Template Comment or Description. Changed Name="Description" to Name="TemplateDescription". Removed ISSUE.
11. Changed Job Ticket ID function to Job Ticket Template ID. Changed Syntax to use JDF node TemplateID attribute instead of Comment Name="JobTicketID". Removed ISSUE.
12. Removed Job Ticket Name function.
13. Changed Job Ticket Version function to Job Ticket Template Version. Changed Syntax to use JDF node TemplateVersion instead of Comment Name="JobTicketVersion". Removed ISSUE.
14. Removed DescriptiveName attribute from Media function and added DimensionName attribute. Renamed PercentRecycled attribute to RecycledPercentage. Removed ColorName and added MediaColor. Removed ColorPool resource. Removed sRGB attribute. Removed ColorName ISSUE.
15. Changed Message To Operator function to use Comment Name="OperatorText" instead of "MessageToOperator". Removed ISSUE.
16. Removed Main and Upper values from Output Bin Name function OutputBin attribute. Removed ISSUE.

17. Removed ProofingParams from Printer Resolution function.
18. Removed SystemSpecified ISSUE from Process Color Model function.
19. Changed Proof Print function to use RenderingParams instead of ProofingParams. Removed ProofType attribute. Removed ContactType ISSUE. Removed ISSUE about Origination and Prepress working group revamping ProofingParams.
20. Removed HoleType ISSUE from Punching and HoleMaking function.
21. Added SlipCopy value to SheetUsage attribute in Start, Separator, and End Sheets function. Removed Slip ISSUE.

B.3 Changes to make version 0.03, March 17, 2003

1. Added "Level 1 and Level 2" to ICS title.
2. Added content to Introduction section.
3. Added content to Terminology section.
4. Changed "Syntax" heading to "Syntactic Fragment" for each function.
5. Added description for "Conformance Levels" heading. Added "Comformance Levels" heading for each function.
6. Changed "Order Pages" function to "Page Order" and fixed description and value descriptions to reflect that the function describes how the pages have already been ordered and not how they are to be reordered.

B.4 Changes to make version 0.04, March 24, 2003

1. Added captions to tables and figures. Added Table of Figures after Table of Contents.
2. Added a statement at the end of section "1.2 JDF Included in the ICS for Digital Printing" to say that combined process node may be part of a job ticket.
3. Added a statement in section "1.2.2 Structure of an ICS for Digital Printing JDF Job Ticket" to say that Activation attribute in a combined process JDF node is always set to Active. Also added an ISSUE.
4. Added a table to section 1.2.2.2 Resources and ResourcePool that lists all JDF Resources/Elements that are supported by the ICS for DP, the feature they are used by, the process(s) they are inputs to or outputs from, their attributes that are supported, and the conformance level.
5. Changed "function" terminology to "feature" in section "3.1 Features Supported".
6. Added statement to section "3.1 Features Supported" to say that features that use the same resource can be combined into a single resource definition in the job ticket. Added an example.
7. Added "(NMTOKEN)" text to description of values that are NMTOKENs in section "3.1 Features Supported".
8. Added text to FileSpec URL describing the format of the URL (e.g. file or http) in Document File Name feature.
9. Clarified FoldCatalog description in Fold feature.
10. Made Media Location LocationName Optional in Media feature

11. Corrected Interleave Sheets feature so that MediaRef is under a Sheet resource.
12. Added JDF Template="true" attribute/value to Job Ticket Template Comment or Description, Job Ticket Template ID, and Job Ticket Template Version features.
13. Changed MediaColor to MediaColorMeasurement for Media resource in Media feature to match updated JDF Spec.
14. Added StockType attribute to Media resource in Media feature.
15. Added None and SystemSpecified to HoleType attribute for Media resource in Media feature. Added ISSUE to address adding SystemSpecified to JDF Spec.
16. Added Cardinal, Cyan, Magenta, Royal, Ruby, and UserColor-n as values for MediaColorName in Media feature. Added ISSUE to address adding to JDF Spec.
17. Added statement to Number Up feature stating that it can be combined with Fit Policy feature.
18. Changed Process Color Model feature to have Page, Document, or Job scope (it only had Job scope).
19. Added an ISSUE to Proof Print feature to see if this is how the JDF should appear.
20. Added description to Range of Pages to Process describing the behavior printing 2-sided.
21. Removed ErrorDiffusion value from ScreeningFamily attribute in Screening Family feature to match updated JDF Spec.

B.5 Changes to make version 0.05, April 16, 2003

1. Added new figure "Example of JDF and JMF workflow interactions" to section 1.22 JDF Included in ICS for Digital Printing .
2. Cleaned up some wording in section 1.2 JDF Included in ICS for Digital Printing.
3. Changed CombinedProcessIndex for ComponentLink in figure "Content of a ICS for Digital Printing Job Ticket" to state that it contains index of DigitalPrinting process or last finishing process.
4. Added wording to section 1.2.2 Structure of an ICS for Digital Printing Job Ticket about the order of commutative processes not being significant. Added an ISSUE about how this interacts with SettingsPolicy.
5. Updated table "Supported Processes and their Resources" to show optional Trapping after Interpreting and after Rendering. Clarified whether Trapping is vector or raster.
6. Added new table " Possible successor processes of each predecessor process" to section 1.2.2 Structure of an ICS for Digital Printing Job Ticket.
7. Added new figure " Process Flow" to section 1.2.2 Structure of an ICS for Digital Printing Job Ticket.
8. Added clarification in section 1.2.2.1 JDF Node that the JDF XML namespace must be declared as the default namespace in the job ticket.
9. Added statement in section 1.2.2.2 Resources and ResourcePool under Status description stating that Input resources are always Available and output resources are always Unavailable.

10. Removed ISSUE in table section 3.1 Features Supported of whether to use SheetIndex and DocSheetIndex. It was decided that BundeltemIndex would be used.
11. For Fit Policy feature, moved Abort and Tile values for SizePolicy attribute from the excluded list and added them as possible values.
12. Added ReferenceEdge attribute to Folding feature.
13. For Margins feature change NonPrintableMargins order from top, rught, bottom,left to left, bottom, right, top.
14. Added MediaColorNameDetails and MediaType attributes to Media feature.
15. Added Coated and InkJet values to Media features BackCoating and FrontCoating attributes.
16. Added Brand attribute to Media feature.
17. Removed ISSUE from Media feature's HoleType, SystemSpecified is being added as new value.
18. Change Media feature's MediaColorName attribute to be an enumeration. Removed Cardinal, Grey, Purple, Royal, Ruby, UserColor, UserColor-*n*. Added SystemSpecified and made it the default. Added "Clear" as a possible prefix.
19. For Media feature MediaTypeDetails, moved Unknown from excluded list and add it as a possible value, and the default.
20. Changed Media feature's RecycledPercentage to be a double instead of an integer. Removed -1 as a value and as the default.
21. Changed CombinedProcessIndex for ComponentLink in Number of Copies feature to state that it contains index of DigitalPrinting process or last finishing process.
22. Added Booklet as a value for Output Bin Name feature's OuputBin attribute.
23. Added Page Distribution feature.
24. Changed Printer Resolution to Device Resolution, changed it to have Page, Document, or Job scope, and Comformance Levels 1 and 2 instead of ?.
25. Added Presentation Presentation feature.
26. Changed Settings Policy description to state that SettingsPolicy can be set for elements as well as resouces. Removed the ISSUE asking whether SettingsPolicy can be set for processes. It was decided that it cannot.

B.6 Changes to make version 0.06, May 23, 2003

1. Added a number of ISSUES that need to be addressed/resolved.
2. Reorganized, rewrote parts of, added new information and sub-sections to sections 1, 2, and 3.1.
3. Made major enhancements to table in Figure 3-7 - Elements Supported in a Digital Printing Job Ticket. Added XPath, Element Attributes, Feature Attributes and Child Elements, and Feature Attribute Values columns.
4. Added section 3.2 Element and Resource Descriptions for a few JDF Elements and Resources to see if the section is of value.

5. Added Elements/Resource Used heading to section 3.3 Features Supported for a few features to see if the heading and its contents are of value.
6. Changed Device Resolution feature to Destination or Physical Printer Resolution.
7. Added mimeType attribute to Document File Format feature.
8. Added RotatePolicy attribute to FitPolicy feature.
9. Clarified descriptions of Disjointing OffsetDirection attribute.
10. Removed typical values for Media feature's DimensionName attribute and referenced PWG Standard of Standardized Media Names.
11. Removed Screening Family feature's ScreeningFamily typical values.
12. Added BestEffortExceptions, MustHonorExceptions, OperatorInterventionExceptions attributes to Settings Policy feature.
13. Added Trapping feature.

B.7 Changes to make version 0.07, June 10, 2003

1. Added notes and ISSUES from 6/3, 6/5, and 6/10 Digital Printing working group meetings.

B.8 Changes to make version 0.08, August 22, 2003

1. Added bundle item example to Partitionable Resources section.
2. Added Approval and ICS Versions to Features Supported section and to Elements Supported in a Digital Printing Job Ticket table.
3. Added explanation of swapping x and y dimension of Media resource to Feed Orientation feature.
4. Added Continuous, Disc, Disc-n, Front, Roll, Roll-n, and Tray to Location element's LocationName attribute in Input Tray Name feature and to Elements Supported in a Digital Printing Job Ticket table.
5. Added TimeStamp attribute to Job Created By and Job Modified By features and to Elements Supported in a Digital Printing Job Ticket table.
6. Split NonPrintableMargins into NonPrintableMarginsBottom, NonPrintableMarginsLeft, NonPrintableMarginsRight, and NonPrintableMarginsTop in Printable Margins feature and in Elements Supported in a Digital Printing Job Ticket table and to Elements Supported in a Digital Printing Job Ticket table.
7. Added S1-generic value to Media resource's HoleType attribute in Media feature and to Elements Supported in a Digital Printing Job Ticket table.
8. Added Disc and Other values to Media resource's MediaType attribute in Media feature and to Elements Supported in a Digital Printing Job Ticket table.
9. Removed Continuous, Paper, Transparency, and Unknown values from Media resource's MediaTypeDetails attribute in Media feature and from Elements Supported in a Digital Printing Job Ticket table.

10. Added Tractor value to Media resource's MediaTypeDetails attribute in Media feature and to Elements Supported in a Digital Printing Job Ticket table.
11. Added MediaUnit attribute with values Continuous, Fan, and Sheet to Media resource in Media feature and to Elements Supported in a Digital Printing Job Ticket table..
12. Removed Unknown value from Media resource's StockType attribute and from Elements Supported in a Digital Printing Job Ticket table.
13. Swap y x to be x y for NumberUp attribute in Number Up feature.
14. Added DirectProofAmount attribute to DigitalPrintingParams resource in Proof Print feature and to Elements Supported in a Digital Printing Job Ticket table.
15. Added S1-generic to HoleMakingParams resource's HoleType attribute in Punching and HoleMaking feature and to Elements Supported in a Digital Printing Job Ticket table.
16. Added IncludeInBundleItem attribute to InsertSheet resource in Start, Separator/Slip, End Sheets feature and to Elements Supported in a Digital Printing Job Ticket table.
17. Removed TrimmingType from TrimmingParams resource in Trimming feature and from Elements Supported in a Digital Printing Job Ticket table.

B.9 Changes to make version 0.09, October 7, 2003

1. Added an abstract to title page.
2. Reworded parts of "1. Introduction" and "1.1.1 What is JDF?" sections.

B.10 Changes to make version 0.09, October 14, 2003

1. Added clarification to Terminology section stating that references to JDF assume that it is the JDF representing a job.

B.11 Changes to make version 0.10, October 21, 2003

1. Added "- JDF Process" to the title of this ICS.
2. Modified Conformance Levels for some features (Comment/Description of Job, Feed Orientation, Fit Policy, Job Name, Jog Offset, Margins, Notification, Page Delivery, and Print Quality) based on the decisions made by the FSG Open Print Job Ticket working group for Conformance Level 1.
3. Changed syntax of Document Compression, Document File Name, Document Format, and Document Natural Language features to not partition by Run if there is only a single document (file) in the job.
4. Changed Folding feature's FoldingParams FoldCatalog attribute's values to be Px-y instead of Fx-y.

B.12 Changes to make version 0.11, November 14, 2003

1. Modified Conformance Levels for some features (Job Priority, and Stapling and Stitching) based on the decisions made by the FSG Open Print Job Ticket working group for Conformance Level 1.

2. Added Approval to list of Other Optional Processes.
3. Cleaned up first paragraph in Resources and ResourcePool section.
4. Added description of intermediate ResourceLink to ResourceLinks and ResourceLinkPool section.

B.13 Changes to make version 0.12, November 21, 2003

1. Added Digital Printing Device to Other Terminology section.
2. Reworded section 3 JDF Supported by ICS for Digital Printing as determined during 11/21 working group meeting.
3. Changed ICSVersions Conformance Levels from ? to "1 and 2".
4. Added ISSUE about whether or not to add a Category feature.

B.14 Changes to make version 0.13, December 8, 2003

1. Fixed descriptions of Force Page feature's SheetUsage FillForceBack and FillForceFront attributes and also added examples with pictures.
2. Renamed Media MediaColorMeasurement attribute to LabColorValue.
3. Changed Notification feature to use new CustomerMessage element instead of NodeInfo NotificationFiler.
4. Updated Input Tray Name feature LocationName attribute's values to match JDF 1.2 Spec.
5. Updated Output Bin Name features OutputBin attribute's values to match JDF 1.2 Spec.
6. Removed all SystemSpecified values.
7. Changed JDFSchema_1_2 to JDFSchema_1_1 per versioning decision.
8. Removed the SystemSpecified value from the Jog Offset feature's Disjointing OffsetDirection attribute.
9. Added S-generic to Media HoleType and removed SystemSpecified as a value.

B.15 Changes to make version 0.14, December 15, 2003

1. Started splitting "Figure 3-9 Elements supported in a Digital Printing Job Ticket" into separate tables for each resource/element.
2. Fixed up text in section 3.1.2 Conformance Levels.
3. Removed X from Approval Approval intersection in Figure 3-1 Possible successor processes of each predecessor process.
4. Added references to Introduction and Overview of JDF sections to see chapters 1 and 2 of the JDF 1.2 Spec.
5. Modified Figure 1-1 Job Ticket Conceptual View to show ResourceLinks and removed arrows.

6. Moved content of Figure 3-3 Combined Digital Printing Node Attributes to new split out table for Combined Digital Printing Node in section 3.1.8 Resources and Elements supported by ICS for Digital Printing.
7. Moved content of Figure 3-5 Resource Element Attributes to new split out table for All Resources in section 3.1.8 Resources and Elements supported by ICS for Digital Printing.
8. Added Optional Intermediate Input Exchange Resources column to Figure 3-6 Supported Processes and their Resources table.
9. Moved DigitalPrintingParams, LayoutPreparationParams, RenderingParams, ScreeningParams, TrappingDetails from Optional to Required column in Figure 3-6 Supported Processes and their Resources table. Added InterpretingParams as a required input resource for the Interpreting process.
10. Added Component as a required output resource for the Approval process in Figure 3-6 Supported Processes and their Resources table.
11. Added Component as a required output resource for one of the CoverApplication, DigitalPrinting, Folding, HoleMaking, SpineTaping, Stitching, Trimming processes. Added a note explaining that only one of the processes will have Component as a required output resource.
12. Added ComponentLink elements with Usage="Intermediate" for the CoverApplication, Folding, HoleMaking, SpineTaping, and Stitching processes in Figure 3-8 Contents of a Digital Printing Job Ticket and renamed figure to Structure and Contents of a Digital Printing Job Ticket
13. Added ApprovalSuccess resources and resource link to Figure 3-8 Structure and Contents of a Digital Printing Job Ticket.
14. Rename section 3.1.7 Content of a Digital Printing Job Ticket to figure to Structure and Contents of a Digital Printing Job Ticket. Clarified when the link for an exchange resource may be present in the ResourceLinkPool.
15. Add ApprovalSuccess resource to Approval feature.
16. Fixed values of ChannelType attribute in Approval, Contact Information, and Proof Print features to match JDF 1.2 spec.
17. Added ChannelTypeDetails attribute to Approval, Contact Information, and Proof Print features.
18. Remove ReferenceEdge attribute from Binding, Folding, Punching and HoleMaking, and Stapling and Stitching features and add ComponentLink with Orientation attribute.
19. In Destination or Physical Printer Requested feature, removed DigitalPrinting as a process for Device resource.
20. Removed File as a value for ChannelType attribute in Notification feature.
21. Added a statement to Number Up feature to use Stapling and Folding features for booklet print.
22. Removed Approval process from Proof Print feature. Made ApprovalParams so that is a child of DigitalPrintingParams in Proof Print feature
23. Added statement to ProofPrint and Approval features that there can be 1 or more occurrences of ApprovalPerson.

B.16 Changes to make version 0.15, January 9, 2004

1. Added note to Supported Processes and their Resources Table stating that in this ICS RenderingParams is a required input resource to the Rendering process.
2. Changed RenderingParams in "Number of Occurrences of Supported Resources" table to be 1 occurrence. Added InterpretingParams as 1 occurrence.
3. Added IsWaste attribute to InsertSheet Resource in Interleave Sheets feature.
4. Continued splitting "Figure 3-9 Elements supported in a Digital Printing Job Ticket" into separate tables for each resource/element.
5. Fixed Proof Print feature so that ApprovalParams is a child of DigitalPrintingParams.
6. Removed DescriptiveType attribute from FoldingParams resource in Folding feature since it is deprecated in JDF 1.2.
7. Removed all statements that defined the length of values that are strings.

B.17 Changes to make version 0.16, January 12, 2004

1. Finished splitting "Figure 3-9 Elements supported in a Digital Printing Job Ticket" into separate tables for each resource/element.
2. Added BASE-ICS reference to References section.
3. Started changing "Scope" heading to "Partition Keys" and filling in valid partition keys that may be used in each feature in Features section.
4. Started adding "Element/Resources Used" heading and linking to specific element or resource tables for each feature in Features section.

B.18 Changes to make version 0.17, January 15, 2004

1. Finished changing "Scope" heading to "Partition Keys" and filling in valid partition keys that may be used in each feature in Features section.
2. Finished adding "Element/Resources Used" heading and linking to specific element or resource tables for each feature in Features section.
3. Added SheetAndSet as a value for Collate attribute in Collate feature.
4. Removed statement that Rotate0 is the default for Orientation attribute in ComponentLink resource.
5. Added CustomerInfo, AuditPool, NodeInfo, ResourcePool, and ResourceLinkPool to Combined Digital Printing Node table.
6. Added ResourcePool and ResourceLinkPool element tables.
7. Added Part element table.
8. Removed list of partition keys from each resource table and feature, put in one place and referenced it.
9. Replaced duplicate consecutive Feature entries in element/resource tables and replaced with "same as above" text.

10. Changed "Description" value of Comment Name attribute to be "JobDescription" in Comment/Description of Job feature. Also changed Comment element table to reflect this change.
11. Removed "Type" heading and contents from each Feature.

B.19 Changes to make version 0.18, February 05, 2004

1. Removed BundleItemSheetIndex from the list of valid Partition Keys.
2. Added ISSUE to partition Media instead of DigitalPrintingParams in Partitioning example .
3. Removed MediaRef from DigitalPrintingParams and LayoutPreparationParams Conformance tables.
4. Removed JMFURL attribute from Device resource in Destination or Physical Printer Requested feature.
5. Added NodeInfo Route attribute to Destination or Physical Printer Requested feature.
6. Changed Partition Keys of Destination or Physical Printer Requested feature to be None.
7. Added ComponentGranularity="BundleItem" in the examples where RunList/@EndOfBundleItem="true" is specified.
8. Added ComponentGranularity to RunList Conformance table.
9. Added Category attribute to JDF (Combined Digital Printing Node) conformance table and to example code.
10. Added Appendix A Changes to Consider for JDF 1.3 and added 2 items to the list.
11. Added an issue to partition Media instead of partitioning DigitalPrintingParams and LayoutPreparationParams to specify different Media.
12. Added an issue to determine if all Intermediate ComponentLinks should each have a corresponding Component resource.
13. Added an issue to determine which (or all) partition keys are valid for each of the conformance levels.
14. Added two tables as discussed by DP WG, one that lists the valid partition keys for RunList and one for resources other than RunList. Changed all references from list of valid partition keys to reference these two tables.

B.20 Changes to make version 0.19, February 06, 2004

The following changes were made as result of comments made during the 06Feb2004 review meeting:

1. Added ComponentType attribute to Component conformance table.
2. Added Status attribute to All Resources conformance table.
3. Added All ResourceRefs conformance table.
4. Removed LayoutElementRef and MediaRef conformance tables.
5. Changed all conformance tables and Elements/Resource Used lists to refer to LayoutElement and Media instead of LayoutElementRef and MediaRef.

6. Removed (D) from SettingsPolicy BestEffort value in JDF Combined Digital Printing Node and All Resources conformance tables.
7. Removed (D) from Disjointing/@OffsetDirection None value in Disjointing conformance table.
8. Removed Disjointing/@OffsetDirection Straight value from Disjointing conformance table and Jog Offset feature.
9. Added FileSpec MimeType values to FileSpec conformance table.
10. Added FileSpec MimeTypeVersion values to FileSpec conformance table.
11. Added FileSpec URL values to FileSpec conformance table.
12. Removed (D) from RotatePolicy Rotate0 value in FitPolicy conformance table.
13. Changed all values for FoldCatalog and NoOp to W? and R? for level 2 in FoldingParams conformance table.
14. Removed (D) from PositionX and PositionY None values in ImageShift conformance table.
15. Removed (D) from IncludeInBundleItem None value in InsertSheet conformance table.
16. Removed (D) from IsWaste true value in InsertSheet conformance table.
17. Removed (D) from BackCoating None value in Media conformance table.
18. Removed Media MediaType attribute's Unknown value from Media conformance table and Media feature.
19. Removed (D) from EndOfDocument, EndOfBundleItem, and EndOfSet attribute's false value in RunList conformance table.
20. Changed DataType of all elements that can be refelements to refelement in conformance tables.
21. Added a Component resource for each ComponentLink in Structure of a Digital Printing Job Ticket figure.
22. Added Component resource for each ComponentLink when Orientation attributes is specified for Binding, Folding, Punching and HoleMaking, and Stapling and Stitching features.
23. Changed definitions of Run in all features to "String that uniquely identifies a specific partition of the RunList".
24. Added Base64, BinHex, MacBinary, UUEncode, ZLIB values to FileSpec conformance table for Compression attribute and to Document Compression feature.
25. Added issues to Document Compression, Document File Format, Document File Name, and Document Natrua| Language to remove "Document" from the names of the features.
26. Changed possible ICSVersions values to DP_L1-1.0 and DP_L2-1.0.

B.21 Changes to make version 0.20, February 13, 2004

The following changes were made as result of comments made during the 12Feb2004 and 13Feb2004 review meetings:

1. Split up ID and rRef and changed descriptions for ID and rRef for all features.

2. Removed last 2 rows of "Partitioning Resources other than RunList" table that listed RunTags/SetDocIndex and RunTags/SetRunIndex as valid partition keys.
3. Added text to the description of the "Conformance Levels" headings in section 3 stating that not all attributes shown for a feature are supported by Level 1, and to refer to the conformance table for the specific element for this information.
4. Added PPML/1.5, PPML/2.0, and PPML/2.1 as examples for MimeTypeVersion in Document File Type feature and FileSpec conformance table.
5. Added specific resource name and what partition keys are valid for each resource under the Partition Keys heading for each feature.
6. Added ISSUE to Number Up feature to determine if RotatePolicy should be added.
7. Changed attribute descriptions in features to specify "If present, MUST be set" instead of "Optional".
8. Changed attribute descriptions in features to specify "MUST be set" instead of not stating anything when required.
9. Italicized value descriptions in features to emphasize that the descriptions are informative.
10. Removed Template attribute from Job Ticket Template Comment or Description, Job Ticket Template ID, and Job Ticket Template Version features and JDF (Combined Digital Printing Node) conformance table.
11. Added OffsetAmount attribute to Disjointing resource in Jog Offet feature and Disjointing conformance table.
12. Fixed descriptions and pictures for SheetUsage attribute's FillForceBack and FillForceFront values in Force Page feature.
13. Removed statement that Abort is default value for SizePolicy in Fit Policy feature and FitPolicy conformance table.
14. Clarified description of Job Created By feature so that it refers to Combined Digital Printing Node instead of Job.
15. Clarified description of Job Name feature so that it states that it is the name that the customer has given the job.
16. Clarified description of Job Ticket Created By feature so that it refers to Combined Digital Printing Node instead of Job Ticket.
17. Changed descriptions of Jog Offet to refer to components instead of job copies and jobs.
18. Fixed descriptions of Disjointing OffsetDirection attribute's values so that the don't state that Left is "next to Right" and Right is "next to Left".
19. Fixed description of Margins feautres to match JDF spec.
20. Removed statement that None is the default value for BackCoating in Media feature and Media conformance table.
21. Removed Recycled attribute from Media feature and Media conformance table.
22. Added statement that Sheet is the default value for MediaUnit in Media feature and Media conformance table.
23. Removed statement that Both is the default value for ImagableSides in Media feature and Media conformance table.
24. Removed statement that Opaque is the default value for Opacity in Media feature and Media conformance table.

25. Changed FoldCatalog attribute's z-fold value back to F6-6 in Folding feature.

B.22 Changes to make version 0.21, February 18, 2004

The following changes were made as result of comments made during the 17Feb2004 review meeting:

1. Changed Comment element's Name="OperatorText" to "Instruction" for Message to Operator feature and in Comment conformance table.
2. Added Language attribute to Comment element in Message to Operator, Comment/Description of Job, Job Ticket Comment or Description, and Media features.
3. Added Language attribute to Comment conformance table.

The following changes were made as result of comments made during the 18Feb2004 review meeting:

4. Added descriptions of URL formats that must be used for Locator attribute in Notification feature.
5. Added an ISSUE asking if the Form value should be included in this ICS for ChannelTypeDetails attribute in Notification feature and ComChannel conformance table.
6. Removed CombinedProcessIndex from ComponentLink when Usage="Output" in Number of Copies feature, All ResourceLinks conformance table, and other example in this ICS.
7. Changed Amount attribute to be a "MUST" be present in Number of Copies feature.
8. Expanded Number Up feature to include specification of Rotate for PageCell and PresentationDirection.
9. Removed Media/MediaRef from all features and examples that contain LayoutPreparationParams. The DP WG decided that in a Combined Digital Printing Node the fact that Media is specified in DigitalPrintingParams allows LayoutPreparationParams to access it to get the Media dimensions. Also removed Media from LayoutPreparationParams conformance table.
10. Added conformance table for PageCell subelement.
11. Added PageCell as a subelement in the LayoutPreparationParams conformance table.

B.23 Changes to make version 0.22, February 20, 2004

The following changes were made as result of comments made during the 19Feb2004 review meeting:

1. Removed ISSUE from F6-6 z-fold since it was resolved on Finishing forum.
2. Clarified Page Order feature description.
3. Added PageCell/FitPolicy/@SizePolicy to NumberUp feature.
4. Added FitPolicy element to PageCell conformance table.
5. Removed the DeviceCMY, DeviceN, and DeviceRGB values for the ProcessColorModel attribute in Process Color Model feature and ColorantControl conformance table.

6. Removed RenderingParams from Proof Print feature. Removed Proof Print feature from RenderingParams and ObjectResolution conformance tables.
7. Clarified description of Partition Key heading in table that is at beginning of Features Supported section.
8. Clarified descriptions of the values for HoleMakingParams/@HoleType in Punching and HoleMaking feature.
9. Removed R6-generic and R7-generic values from HoleMakingParams/@HoleType in Punching and HoleMaking feature and HoleMakingParams conformance table.
10. Rewrote description for Pages in Range of Pages to Include and Range of Pages to Output features.

The following changes were made as result of comments made during the 20Feb2004 review meeting:

11. Clarified descriptions of the values for Media/@HoleType in Media feature.
12. Removed R6-generic and R7-generic values from Media/@HoleType in Media feature and Media conformance table.
13. Added ISSUE discussing proposal to remove CombinedProcessIndex from ICS and when it MAY and MUST be specified.
14. Removed ISSUE from Range of Pages to Include feature and changed description to state that pages will be imaged on consecutive sheets sides.
15. Changed name of Rotate Page feature to Rotate Sheet Content.
16. Changed name of Screening Family feature to Screening and added ScreenType attribute to feature and ScreenSelector conformance table.
17. Updated descriptions of SettingsPolicy values in Settings Policy feature.
18. Updated descriptions of Sides value in Sides feature.
19. Removed Figure 3-3 Logical Producer - Consumer Diagram. Will add Reference Model diagram to earlier section in this ICS.
20. Changed name of this ICS from "ICS for Digital Printing" to "Digital Printing ICS" throughout this ICS to match names used by MIS ICS and Base Conformance ICS.

B.24 Changes to make version 0.23, March 02, 2004

The following changes were made as result of comments made during the 25Feb2004 review meeting:

1. Updated Ws and Rs for Conformance Levels 1 and 2 in JDF (Combined Digital Printing Node), All Elements, All Resources, All Resource Links, Address, and ApprovalParams conformance tables.
2. Added Job Identification feature.
3. Added Named Features feature.
4. Added MIS Support feature.
5. Added MediaRef conformance table.

6. Added Annex B <Additions to Consider for Next ICS>.
7. Updated ISSUE in ResourceLinks and ResourceLinkPool section that discusses when CombinedProcessIndex must be specified to include case where an optional input resource is present.
8. Added examples to Input Tray Name feature using Media partitioned by Location and two Media resources.
9. Added examples to Media feature using Media partitioned by Location and two Media resources.
10. Added row to Part conformance table for MediaRef.
11. Added Location attribute to Part conformance table.

The following changes were made as result of comments made during the 02Mar2004 review meeting:

12. Changed name of this ICS from "Digital Printing ICS" to "Integrated Digital Printing ICS" throughout this ICS.
13. Marked Introduction section and Scope section as blue text which means that they are to be included in IDP ICS and not the IDP Application Notes.
14. Added Reference Model and Digital Printing section after Introduction and included Reference Model diagram.

B.25 Changes to make version 0.24, March 05, 2004

The following changes were made as result of comments made prior to the 05Mar2004 review meeting:

1. Added JobSubmitterName and JobName as value for ShowList attribute in Start, Separator/Slip, End Sheets feature and in JobField conformance table.
2. Added SetDocIndex row to "Partitioning Resources other than RunList" table.

The following changes were made as result of comments made during the 05Mar2004 review meeting:

3. Removed Partition Keys list from all conformance tables.
4. Added PartIDKeys attribute and with RunIndex and DocIndex as valid values to all conformance tables where PartIDKeys is valid.
5. Updated Ws and Rs in JDF (Combined Digital Printing Node) through Device conformance tables. Highlighted in turquoise and hid text for rows and table that won't appear in IDP ICS but will appear in IDP Application Note.
6. Removed Conformance Level 1 Desktop from this ICS and renamed Conformance Level 2 to Conformance Level 1.
7. Removed Conformance Levels heading from all features in features section.
8. Highlighted in turquoise and hid the Process bullet for all conformance tables so they won't appear in IDP ICS but will appear in IDP Application Note.
9. Added DescriptiveName attribute to JDF node in Job Name feature and JDF Combined Digital Printing Node conformance table.
10. Added DescriptiveName attribute to Media feature and Media conformance table.

B.26 Changes to make version 0.25, March 09, 2004

The following changes were made as result of comments made during the 08Mar2004 review meeting:

1. Updated Ws and Rs in DigitalPrintingParams through ResourcePool Conformance tables. Highlighted in turquoise and hid text for rows and table that won't appear in IDP ICS but will appear in IDP Application Note.
2. Added [DP-AppNote] reference.
3. Added ProductID to Media and Component conformance tables and MIS Support feature.
4. Remove ProductID from All Resources conformance table.
5. Moved ID from All Resources conformance table to All Elements conformance table.
6. Removed Created and Modified conformance tables because they are in the Base ICS.
7. Removed most of the sections in the back of this spec.

The following changes were made as result of comments made during the 09Mar2004 review meeting:

8. Added Directory attribute to RunList conformance table and Document File Name feature.
9. Added NPage attribute to RunList conformance table and Document File Name feature.
10. Removed (D) from ScreenType value and made it "?" in ScreenSelector conformance table.
11. Changed "This ICS" to "This application note" where appropriate.
12. Added multipart/related value for MimeType in FileSpec conformance table and in Document File Format feature.

B.27 Changes to make version 0.26, March 12, 2004

The following changes were made as result of comments made during the 08Mar2004 review meeting:

1. Updated System Reference Diagram to adjust where dashed lines go and add legend.
2. Replaced Usage="Intermediate" with PipeProtocol="Internal" for changing the Orientation of an exchange resource.
3. Filled in the Conformance Section 4 along the lines of the approved Base Conformance ICS.
4. Spell checked the entire document.